

## Woodless Construction Unstabilised Earth Brick Vault and Dome Roofing without Formwork

by John Norton



# Woodless Construction Unstabilised Earth Brick Vault and Dome Roofing without Formwork

by John Norton, Development Workshop



*John Norton's interest and involvement in human settlements development began when he and fellow architectural students and Development Workshop co-founders, Allan Cain and Farokh Afshar, helped set up and then run the pioneering "Indigenous Building and the Third World" studies unit at the Architectural Association in London in 1973. This led to extensive field work in Egypt, (including working with the by then famous Hassan Fathy), and in the Sultanate of Oman, and to the founding of "Development Workshop", an international, not-for-profit organization, now celebrating its 25 years.*

*The group's initial tenet – that learning from and strengthening indigenous planning and building processes and techniques is as important as teaching new skills – is still at the core of DW's present work.*

*John Norton has worked extensively in many countries of Africa and Asia, always strengthening the use of local human and material resources to attempt to make sustainable improvements to local building and planning practices that come under ever increasing pressure in a changing world. A major focus of his work is naturally on training, at all levels, but also increasingly on enabling locally staffed organizations to initiate and manage their own development programmes with minimal outside intervention, a slow but ultimately inevitable requirement for sustainable development.*

*A concerned member of the increasingly de-populated agricultural community of South West France, where he lives with his wife and two children, John Norton finds striking parallels between his work and the rural and urban problems confronting much of contemporary Europe.*

*He has published extensively and is a regular (bilingual) visiting lecturer in many countries.*

## Contents

---

Acknowledgements	4
1 Introduction	4
Problem	4
Method	6
Organisation of the report	6
2 General considerations	6
World wide experience of earth roof construction without wood or shuttering	6
Technical options	8
Woodless construction technology	9
Technical description and key technical issues	9
Training	12
Aspects requiring further development or improvement	13
3 Recommendations	14
Constraints and criteria for deciding if woodless construction is suitable	14
How to choose the appropriate technical option	16
How to introduce the construction technique	17
4 Case study: woodless construction in the Sahel	18
Background	18
Earth building and earth roof building in the area	19
Choice of technical options, and criteria affecting this choice	19
How people are taught	20
What modifications have been made to the original technologies?	21
What the impact has been	23
5 Ecological and economic comparison with other buildings	24
A final observation	25
Bibliography	26

## Acknowledgements

---

Writing this Building Issue would not have been possible without drawing upon the work and experience of all the field members of local woodless construction activities throughout the Sahel, and especially in Niger, Mali and Burkina Faso, and above all of the masons themselves, who over the years have all been at the base of developing the programme and adapting the techniques. I am especially grateful for the contribution of Peter Tunley, Development Workshop associate, specialising in the technical development of woodless construction, and Marie Line Uhde, Development Workshop consultant, who has been responsible for much of the field research on the links between Habitat and Environment. Development Workshop is also grateful to all our partners, both for funding and for practical collaboration, who have contributed to the development of woodless construction in the Sahel.

*John Norton*

Director, Development Workshop

March 1998

## 1 Introduction

---

### Problem

Earth is one of the first building materials used by man and even today a large share of the dwellings in the world are constructed with earth as a building material. Sun dried earth was the most commonly used building material in Europe until the middle of the 19th century. Today one finds modern earth construction in Europe and in the USA only on a small scale, and principally as a type of “ecological” housing seeking to promote a sound and sustainable environment. The use of earth as a building material has often been connected to a lack of wood. This is common particularly when it comes to low-income housing in developing countries either because it is no longer possible (and in some cases illegal) to simply gather wood as before, or because the poor cannot afford the cost of buying wood.

“Woodless Construction” has been developed in the sub-Saharan Sahel during the last 20 years. This is a concept for constructing the entire structure of the building – walls and roofs – without wood, using hand-moulded earth bricks. This experience is particularly interesting since a continuous development of technology has taken place responding to actual functional and technical needs and limited economic resources. This comprehensive experience is well known in the region and also documented in some publications in French.

### Background

In many regions of the world, shelter has traditionally been achieved with earth or stone walls and with flat or sloping roofs that are made of timber covered by earth. The buildings produced with these materials have ranged from simple shelters to structures of great sophistication and quality.

The attractiveness for many builders was that the earth and the wood were materials easy to obtain and use, and affordable. In many instances, both could be collected for little or no cost.

However, whilst a variety of materials have been used for building masonry or framed walls, where timber was not readily available to provide the structure for roof building, there were fewer alternatives.

Where wood was in short supply, one answer was to build roofs where the material for covering – such as stone or earth<sup>1</sup> – provided the supporting structure at the same time, in the form of vaults and domes. This practice produced the thin earth shell dwellings and grain stores in central and western Africa, and the more substantial masonry domed and vaulted structures of North Africa and the Middle East. Stone and fired brick masonry domes and vaults were equally chosen by builders in Europe to provide durable structures, and corbelled stone domes can be found in many areas of Europe.

Where the shortage of wood was extreme, as in the deserts of present-day Iran (*Fig 1*) or along the Nile valley, not only were earth domed and vaulted roof structures developed thousands of years ago, but the techniques that developed enabled the roof to be built without any support-

---

<sup>1</sup> Other examples are igloos made with snow, and the reed structures in the marshes at the mouth of the Euphrates, documented amongst others by Wilfried Thesiger's classic photographs in *The Marsh Arabs*, Longmans, Green & Co Ltd, London, 1964.



Fig. 1 Mud brick vault and dome roofscape in the traditional city of Yazd, Iran.



Fig. 2 Timber in a flat roof of a house in the Sahel: vast quantities of beams and branches are used.

ing formwork during construction. This meant that hardly any wood was needed during construction, and none in the finished structure. In both Egypt and Iran and neighbouring countries, a roof technology developed that made use of earth – a readily available local material; responded to the absence of timber for building; and allowed builders to construct a very wide variety of structures that in addition could contribute to good climatic comfort, high quality and durability.

#### The basic issue – depletion and scarcity of resources

The same problem of timber shortage is being encountered in the 20th Century in the Sahel countries of West Africa. Apart from thin earth shell granaries, wood and branches have traditionally provided the support or the reinforcement for the majority of buildings (Fig 2). However, over-consumption and natural factors have led to a drastic depletion of the tree resources in the immediate sub-Saharan Sahel region. The problems are essentially:

- for the population, the lack of resources at two levels: lack of access to affordable organic materials (timber, branches...); and conversely lack of resources to afford alternative non local products;
- the accelerating depletion of trees stocks;
- the negative effect that tree depletion has on the environment and the future of the region.

The Sahel thus typifies many other parts of the world facing similar environmental decline and poverty,<sup>2</sup> and those countries where the problem has already existed for many centuries (Iran, Egypt, Afghanistan, etc.).

However, the perception of the essential issue is not always the same. Local people may be concerned primarily with the difficulty they experience in obtaining wood with which to build, with the deteriorating quality of what wood they *can* find (and thus its shorter durability), and with the typically unattainable cost of alternatives. States and aid agencies, on the other hand, often focus more on the impact of over-consumption of trees on the environment in a longer-term perspective.

#### Problems in replacing traditional practices with modern alternatives

Technical and material alternatives to traditional roofing practices are available in many less developed and arid countries, but in many cases this availability is illusory or very restricted. Non-local or imported resources are frequently not affordable, and in many instances, such as that of corrugated roof sheeting, they do not on their own provide the same climatic protection that was achieved with the traditional wood and earth roof. Woodless construction can bridge the gap between accessibility and affordability on the one hand, and quality on the other: it aims to provide a durable roofing system, using materials that are locally available, whilst contributing to a climatically comfortable built environment.

Affordability and performance are not the only issues in introducing new building techniques into the local building “vocabulary”. Changes in the local context may have precipitated the urgent need to consider new methods or materials, but the process of introducing such change is itself a complex and above all a slow one. Several key issues stand out.

- The poorer the community, the less people are prepared to take risks with unproven innovation, and it therefore requires time for a “product” to achieve local acceptance.
- Dealing with the *transfer* of a traditional process established elsewhere means adapting the way that this has been passed on to new users. In Iran, vault and dome techniques were passed from father to son, from master builder to apprentice, over a decade or indeed much longer. Innovative programmes in a new context require methods allowing much faster training, measured in weeks and months instead of years. This in turn requires changes to both the technique, and to the method used to teach it, to suit the new context.
- A technique, however apparently viable, cannot be assumed to be acceptable to a new community, but needs to be assimilated. Assimilation of vault and dome roofing shows that it needs to be able to merge and adapt to local styles and local conditions. These range from “hard” (measurable) characteristics (rainfall, soil type, etc.) to “soft” (socio-cultural) features (how the home is used,

<sup>2</sup> See for example the Namibian Clay House Project which trained local builders to use Woodless Construction techniques learnt in the Sahel; also the Nubian vault and “parabolic house” introduced to Ladakh, northern India, in 1986, and to Bolivia in the early 1990s by DIB, the Danish International Human Settlement Service.

who does maintenance work, what decorative styles or symbols are important, etc.).

This report deals with the introduction and use of vault and dome roofing built without supporting formwork, and with hand moulded unstabilised earth blocks. "Woodless Construction" is the name that has been given in the Sahel region of West Africa to these techniques.

The object is to describe the woodless construction building techniques as promoted by Development Workshop and the criteria that led to their choice, and to consider the process by which these techniques have been introduced and adapted. The case study underlines that the techniques have to be adapted to very local contexts, and that there is no one standard *method* that can be applied.

## Method

Written as a desk study, this report is nevertheless based on one aspect of Development Workshop's 25 years' field work in less developed countries, namely the experience since 1980 of promoting unstabilised earth vault and dome roof construction in the Sahel. Recent literature has also been reviewed as background material for the study.

## Organisation of the report

The report consists of two parts.

The first (Chapters 1 – 3) outlines the problem, considers different experiences world-wide and the criteria that affect the choice of technique, and gives a description of the woodless earth roof construction techniques.

The second (Chapter 4) consists of a case study of the Woodless Construction Programme in the Sahel countries of West Africa where these techniques have been successfully introduced.

## 2 General considerations

### World wide experience of earth roof construction without wood or shuttering

#### Origins

Masonry vaults and domes built without formwork have their roots in a long tradition of building in the arid areas of the Middle East, as distinct, for example, from Roman vault structures that required a supporting formwork during construction. With very little wood available, over the centuries the builders of present-day Iran and Egypt developed this solution of building with earth as a way of meeting their shelter needs, ranging from palaces to simple houses. The results were often spectacular, and very durable.

"Nubian" vault and dome techniques developed in the arid region of the ancient Nile valley kingdom three thousand years ago or more. In present-day Iran and its neighbouring countries (Syria, Iraq, Afghanistan), but also in China, similar techniques developed, with a greater variety of shape and building method than in Egypt. In Iran unstabilised earth brick vault and dome building has been at the heart of building tradition in the centre and south of the country for centuries. Although in recent years the use of unfired bricks has been in decline, fired brick vaults, and, to a lesser extent, domes, are still in constant use in conjunction with steel I beams in Iran. Similarly, un-shuttered fired brick vaults and domes have also been a significant building technique in Tunisia, where again one progression has been from a traditional vault form with a quite pronounced curve, towards much flatter masonry roofs that depend on the restraint of a reinforced framework<sup>3</sup>, fulfilling a function similar to the I beams used in almost flat domes in Iran. These techniques with fired bricks have in common that they do not require a supporting formwork during construction, but rely on gypsum plaster to achieve a quick-drying and very adhesive mortar.

#### 20th Century experience

In the 20th Century, the desire to find building solutions that would be at least economic, and if possible affordable by low income groups, encouraged renewed interest in earth vault and dome roofing. At least from the 1940's onwards, a number of pilot projects experimented with masonry vault building, although in the majority of cases they made use of formwork to support the structure during construction. This formwork added a cost factor typically putting it beyond the reach of the spontaneous building activities of low income groups that needed to respond to a variety of needs and building forms. (Hence, amongst other reasons, the primary emphasis in this report on techniques that do not require shuttering.)

The Egyptian architect Hassan Fathy (1900 – 1989) is most widely recognised for having pioneered the revival of "Nubian" vault and dome building techniques from 1941 onwards, notably in the building of the New Gournia village (1948), his main project aimed at realising an architecture for low income groups (Fathy, 1973). The project in itself was not a success, but the example was immensely important. Fathy promoted the use of unstabilised earth vaults

<sup>3</sup> Known locally as the Hassad vault, named after the mason who promoted them, these are actually very flat domed structures developed in northern Tunisia.



Fig. 3 The house of Hamed Said, Hassan Fathy's first building using vaults and domes in Egypt.

and domes throughout his career, as well as building similar structures in stone, even though the majority of his projects were ultimately for wealthy clients (Steele, 1989) (Fig 3). Ramses Wissa Wasef (1911 – 1974) was another Egyptian pioneering architect and teacher interested in reviving traditional Egyptian crafts, and notably weaving. His vault and dome covered complex of buildings forming an Arts Centre in Haraneya, on the outskirts of Cairo, initiated as a weaving centre in 1952, is a striking example of “the harmony between craft production and architectural environment” (Taylor, 1990).

Fathy's example inspired many to wish to make use of these techniques. At one end of the scale, the work of Abdel Wahid El Wakil exemplifies the use of traditional Egyptian vault and dome roofing in prestige projects (El-Wakil, 1981). More socially oriented, and aiming at the shelter and settlement problems of poorer communities, Development Workshop, having worked with Fathy in the early seventies (Fathy, 1986), continued to develop this approach initially in the context of rural development programmes in Iran. Here, working on the provision of communal facilities up till 1979, Development Workshop made use of the sophisticated and diverse Iranian vault and dome building techniques, building both with fired bricks (Fig 4), and with stabilised and unstabilised earth bricks. Following Fathy's example, Development Workshop also contributed to the appreciation of these techniques through publications and exhibitions in the 70's<sup>4</sup>. Development Workshop's experience in Egypt and Iran and later in Tunisia lies at the origin of the Woodless Construction Programme in the Sahel.

It was also in the Sahel in the late 70's that ADAUA<sup>5</sup> began a series of projects using vaults and domes, in this

Fig. 4 The roof of the Niazabad public bath: in the '70s Development Workshop promoted the use of traditional Iranian vault and dome roofing in a series of public buildings in western Iran.



case built with stabilised compressed earth blocks, notably in the group's Popular Habitat project at Rosso, Mauritania, and later with gypsum plaster domes for their housing project in Nouakchott (1985). Despite carrying out a series of major building projects, the ADAUA experience did not translate into replicable and spontaneous vault and dome building outside the “project” structure, in part because the informal sector was able to propose cheaper sand cement blocks and metal sheet roofing to the same target “clients”<sup>6</sup>, but also because *structural* deficiencies were frequently encountered in the buildings.<sup>7</sup>

From the 70's onwards, other individual projects were experimenting with the use of vaults and domes in the Sahel using stabilised earth. These included work promoted by groups such as the French association of volunteers for progress, AFVP. In Senegal in the early 1980's Fabricio Pedroza also continued work started in Angola on corbelled dome construction, with fired bricks and later with special cement blocks, aimed at school building. These masonry roofs failed, however, to achieve wider application.

In parallel, considerable research by organisations such as BREDA<sup>8</sup> was attributed to developing school roofing systems with vaults, but these too used formwork during construction.

Overall the range of experience in northern and sub-Saharan Africa has been considerable, but in essentially all instances of vault and dome use with stabilised earth, plaster or cement, there have been major difficulties in resolving the problem of waterproofing (Theunynck, 1994). The measures adopted to address this problem – placing layers of bitumen, or putting on special products such as bitumen-coated aluminium-backed sheets (similar to the sack cloth and tar used traditionally in fired brick roofs in Iran), or relying on cement coatings – have contributed an added

4 These include Development Workshop's exhibition, *Indigenous Building and the Third World*, first shown in Teheran in 1976 and commissioned in a larger version for the United Nations Habitat I conference held in Vancouver in 1976.

5 *Atelier pour le Développement d'une Architecture et d'un Urbanisme Africains*.

6 Serge Theunynck calculates that the house ADAUA's master mason, Mamadou Sarr, built for himself in 1982 cost 66% more per usable m<sup>2</sup> than the cement/corrugated iron alternative. See Theunynck, 1994, p. 778.

7 With reference to the Nouakchott project, Serge Theunynck summarises these as under-estimation of horizontal stress of the domes on the walls, which were built with no ring-beams or buttresses; the poor quality of the plaster used for bricks and mortar; and bad bonding (poorly filled masonry joints). The collapse of 2 domes in 1988 and major cracking resulted in the rehousing of the residents. (Theunynck, 1994)

8 Unesco's regional office for education in Africa based in Dakar.

cost. In the case of cement coatings, in addition they have been consistently prone to cracking and damaging water infiltration. In terms of performance and added cost, these factors have discouraged popular adoption.

Fired brick vaults and domes have also been used in several projects, including the well insulated double skin domes of projects by Fabrizio Carola in Mauritania and Mali. Here, his related work on developing the firing of bricks using rice husks as fuel was also of interest but difficult to sustain on a wide scale because of fuel availability. One can compare this with the experimental work of Nader Khalili's *Geltaftan* in Iran, and later in California<sup>9</sup>, in firing completed earth vault and dome structures from the inside (and latterly from the outside) with oil based products, to achieve a ceramic finish that aimed to increase durability, a process inspired by the numerous artisan brick kilns in Iran. Also in North America, the work of the Dar al Islam Foundation in New Mexico to build their mosque and religious school, designed by Hassan Fathy, was one of the first to use Egyptian vault and dome roofing techniques in that region.

Examples in Latin America have been more limited, although it would be unfair to pass by the spectacular catenary vaulted brick large span structures, albeit built with formwork, by the architect/engineer Eladio Dieste, where vault spans of 50 metres have been achieved in Montevideo, Uruguay, and in Brazil<sup>10</sup>. Likewise in Australia, as in central and southern Africa, there are a few examples of contemporary work with vaults and domes. In India, the prototype projects of the Passive Solar Energy Group and Gernot Minke have tested computer generated dome forms inspired by the middle eastern experience, which have interesting similarities to the dome shapes built by Development Workshop and Fabrizio Carola. Un-shuttered vault and dome building has played a much smaller role in 20th century Europe, with a few individual examples, but CRATerre-EAG<sup>11</sup> has made a significant contribution by including vault and dome roof construction as part of their earth construction course activities in Grenoble, France, and by contributing to improving the international recognition of these techniques through their publications.

## Technical options

### Choice and criteria

This necessarily brief overview of world-wide experience at least serves to demonstrate that at project and prototype level there exists a wide range of options for building with vaults and domes. However, if the aim is partly to be popularly accessible, as in the case of woodless construction, this implies the following criteria, which in turn narrow the material and technical choices and how these can be taught:

- The roofing technique should make substantial use of genuinely local materials, that can be transported by local means.
- The production and use of the building materials should differ as little as possible from existing local practices

where these are seen to perform perfectly adequately in the local context.

- The materials should exist in sufficient local quantity to satisfy a general demand for building materials.
- The roofing (and wall building) process should require as little specialised equipment as possible, so that lack of these items does not become a reason for not using the technique.
- The roofs should be built without needing a supporting formwork during construction, since formwork represents a significant piece of site equipment for builders to obtain and move around, as well as reducing flexibility in the size of roof one can build.
- The techniques should be relatively easy to learn.
- The techniques should be able to resist or attenuate the effects of the local climate.
- The techniques should be durable.
- The techniques should be affordable to low income groups.
- Once given the skills, the techniques should lend themselves technically and economically to spontaneous building by local builders and the local population.
- The techniques should be sufficiently flexible to adapt to different local habits, styles, spatial requirements and building needs.

To these one can add several desirable advantages, such as:

- promotion of local income generating activities through developing local skills and using local materials;
- restoring pride in an environment where building quality has become increasingly difficult to achieve and maintain.

### Which technique to choose?

Which technique to choose will always depend on the local context and one cannot generalise. The state of the local economy, the climate and type of materials available are all deciding factors, but by no means the only ones.

Where fired bricks and gypsum are readily available these are potentially suitable materials, and the example of Tunisia and Iran has shown their widespread use. Where fuel for firing bricks is not available to satisfy needs greater than "one off" projects, or where cement is a costly (and often imported) product, these can preclude their use for low income construction, although in urban areas the economy which can be achieved in building thinner walls with stabilised or fired bricks may justify the added material cost.

Above all, the context may change. Mud bricks were a plentiful local material in the Nile valley, until the dams stopped annual flooding and renewal of mud supplies. Given the increasing scarcity of wood in conditions such as those of the Sahel, where the population is very poor, and where hand made unstabilised earth blocks are already the main wall building material, using the same earth bricks for roof building is a logical extension.

9 *Geltaftan* is a term coined by Khalil from *gel* – clay – and *taftan* – firing or baking. See Khalili (1983) for extracts from his book *Racing Alone*, published by Harper and Row.

10 Morales, Carlos, *Eladio Dieste*, in *Mimar: Architecture in Development* no. 41, 1991.

11 The International Centre for Earth Construction – School of Architecture of Grenoble.

Water resistance of earth roofs is a central issue in choosing which technique to use. We have already noted (Theunynck, 1994) the problems and costs associated with waterproofing vaults and domes built with stabilised earth, plaster or cement roofs. In the case of unstabilised earth vaults and domes, the arid conditions of upper Egypt did not really test their water resistant qualities. The example of Iran, on the other hand, did: earth vault and dome roofing has been widely used in regions of Iran where winters have long periods of both rain and snow. These regions have shown that earth based plasters, although requiring annual maintenance, do provide good – and affordable – protection. Earth plasters are cheap and accessible and easy to repair. For the Sahel, with a pattern of short, but often violent, rain storms, and where traditional earth granaries have already proven the durability of earth in these conditions, unstabilised earth walls and roofs covered with earth plasters are a functional and affordable building choice.

Formwork for building the roofs makes learning easy, but adds to the equipment required and reduces flexibility and the ability to have a building system that can be adapted to local needs. Building without formwork provides flexibility – and the example of Iran shows just how diverse the use of vaults and domes can be, ranging from cinemas with a single vault, to providing agricultural sheds. Vault building without formwork in Egypt required learning to work by eye, and in Iran, both vault and dome building was a skill handed down through generations and again relying on the eye and skill for controlling the form of the roof.

For ease of learning, despite some loss of the flexibility of the Iranian roof systems, the traditional Egyptian method of building domes using a string to position each brick in the dome has pointed the way towards making this process easier to learn quickly. The “catenary” (or inverted chain) shape of the Nubian vault also provided a strong form that could be built with safety by apprentice builders. These were therefore the original techniques that Development Workshop selected to introduce into Niger in 1980, techniques which have since then been the object of continued adaptation to make them both easier to learn, stronger and better suited to the Sahel context.

## Woodless construction technology

### The aim

Introducing woodless construction techniques using hand made unstabilised earth bricks has been aimed at:

- providing builders, and through them, the population, with an affordable roofing technique using a genuinely locally available material – earth – to achieve durable and good quality buildings;
- contributing to reducing the depletion of tree resources and the degradation of the environment.

### The potential and the contribution

Based on using local resources and labour, unstabilised earth vault and dome roof construction has greater potential in areas where other resources are scarce, where labour is plentiful and where the context is suited to these techniques.

Technically, these potentials include the following:

- techniques which are suited to assimilation by local builders and the local population;
- techniques suited to application both in the formal and informal building sector, and thus suited to building simple shelters and houses when the other local resources (wood, straw, etc.) become scarce and for building larger public facilities meeting high standards of comfort and cleanliness and responding well to modern needs;
- stimulating local economies at national and village level and developing local skills by using the materials and builders already in the existing building process; this is particularly significant for public buildings, often heavily dependent on non local materials and external skills;
- being highly labour-intensive, they require – in their simplest form – very little special equipment; this makes them well-suited to countries with large under-employed labour forces and little capital available for investment;
- helping to reduce imports (of building materials or the energy resources needed to produce them) which are crippling the economies of many developing countries.

Environmentally, the saving in wood used in the roofing of flat timber roofs can be considerable. In Mali, for example, a vault or dome roof on a 30 m<sup>2</sup> building saves more than 60 metres of timber beam and 12 m<sup>3</sup> of branches that would have been used traditionally.

Architecturally, vault and dome roofing techniques provide the potential to cover a variety of different spaces, both in size and shape. The combination of several vaults and/or domes can be used in simple or more complex combinations to satisfy a variety of building requirements.

## Technical description and key technical issues

Building roofs with earth vaults or domes requires considering the complete building from the ground upwards, and the condition of the site it stands on. However, understanding the structure of the vault and dome is essential for appreciating the needs of the supporting structure.

### The bricks

The walls and foundations are built with large earth blocks. For walls between 380 and 400 mm thick, bricks need to be at least 190 mm wide when laid as headers only, to ensure a good overlapping bond between successive brick courses, and widths up to 240 mm can make very strong walls. The bonding of bricks in the corners has to be determined in accordance with the brick dimensions, and in all cases bricks should be laid symmetrically over the joint between the two bricks on the layer below. The weight of the bricks varies depending on density. An average *wall* brick, about 110 – 120 mm thick, will weigh in the order of 18 kg. Larger bricks are hard to work with because of this weight.

Roof bricks in the case of the Sahel Woodless Construction Programme measure 200 × 150 × 60 mm.

All the bricks are laid in a mud mortar.

### The Nubian vault

The basic vault form is very similar to that of an inverted catenary, the form taken by a chain suspended from its two ends, and thus, for the chain, a shape in pure tension. Mud bricks being strong in compression and very weak in ten-

sion, it is important that the vault's shape keeps the forces in compression. Inverting the form of the catenary provides this form, and the traditional Nubian vault coincidentally respected this shape closely. In the Woodless Construction Programme, this shape has been slightly modified to take account of extra loading over the sides of the vault, and this new shape is also very easy for the novice builder to draw.

Each vault is built up in a series of vertical courses which incline towards an end supporting wall (*Figs 5 and 6*). The shape of the vault, the inclination of the courses, and the stickiness of the mud mortar, combine to keep the bricks in place during construction without shuttering. To start, the vault shape is traced with strings or wire onto the end supporting wall.

In the Woodless Construction Programme, to facilitate keeping the vault alignment straight, the traditional practice was changed to building vaults from both ends of the room being covered, so that guide strings could be stretched from one end wall to the other.



Fig. 5 Starting building out the vault from the end wall.

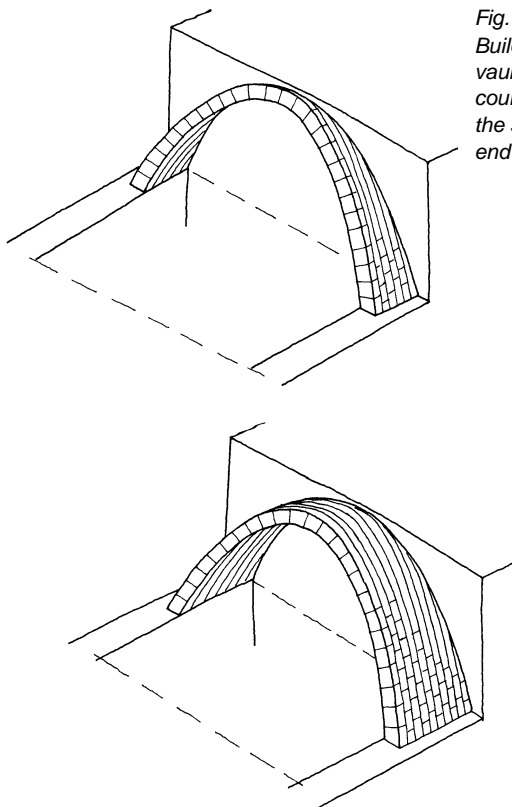

Fig. 6 Building the vault in curved courses out from the supporting end wall.

In building the vault, it is important that the outward thrust onto each supporting wall is contained and transferred to the ground. This is achieved by making the supporting wall thick enough, or by providing a counter-thrust in the form of an adjacent roof. Understanding and compensating for the effect of the vault's outwards thrust enabled Iranian builders to build much flatter vaulted roofs than were common in Egypt.

**The dome**

The basic dome shape used in the Egyptian tradition is hemispherical. Horizontal, concentric courses of unstabilized mud bricks are laid first at a shallow angle and then more sharply inclined as one builds the concentric rings higher and towards the top.

The distance from the centre of the dome and the angle of each brick is given to the builder by a wire or a radial arm which rotates around a central post (*Figs 7 and 8*). Bricks are placed side by side until a complete concentric circle of bricks is closed, to form a compressive ring.

Single domes can cover rectangular or round spaces. To build a dome made up of concentric circles of bricks on a rectangular base requires using one of two techniques:

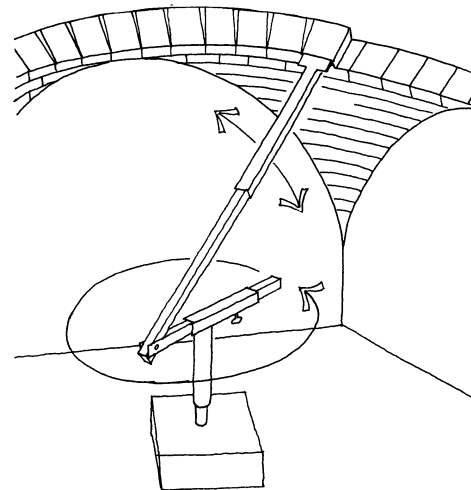

Fig. 7 The radial arm that is used to locate every brick in the dome.



Fig. 8 Using the radial arm in dome building. The arm gives the placement and the angle of every brick.

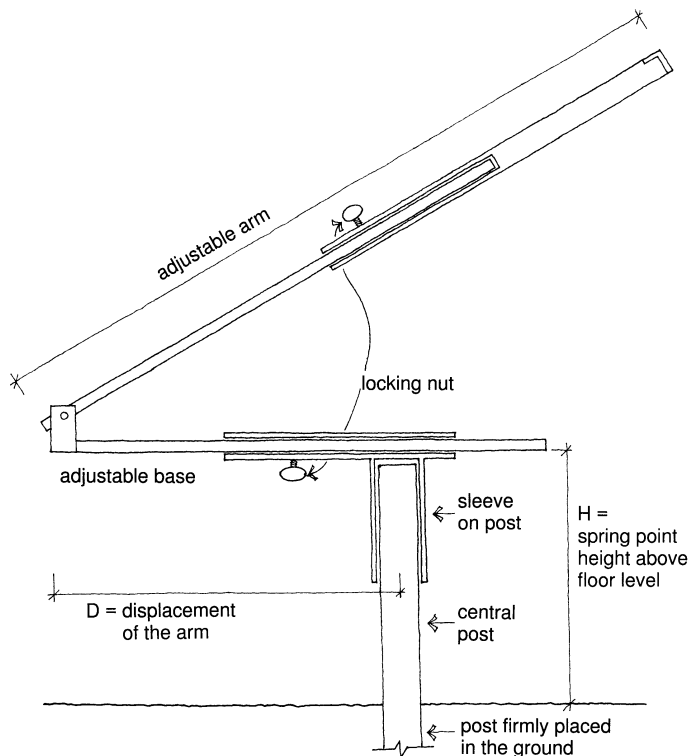

Fig. 9 Details of the rotating radial arm.  
Both the displacement and the radius are adjustable.

- either building pendentives, which are the spherical triangles formed at the intersection of the lower part of a dome with the corner formed by two walls;
- or building squinch arches, i.e. arches that bridge across the interior angle formed by two walls, and over which the curved based of the dome can be built.

Pendentives are much easier for a novice builder to construct, as each brick can be positioned with the radial guide.

The hemispherical dome shape produces external thrust in the lower part of the structure, which does not suit the use of unstabilised earth bricks. Like the vault, the same concern applies – sending the forces of a dome down to the ground. One can help achieve this by lowering the spring point of the dome and making the angle of the dome sides steeper. In the Woodless Construction Programme the position of the guiding arm is displaced away from the centre of the dome, so that the base of this guide rotates *round* the central point. The modified dome shape is stronger, and without lowering the overall height of the roof, the spring point is lower. The mobile guide (Fig 9) is the one piece of equipment that trainee builders are given, although simple domes can still be built without it using the centrally placed wire.

Several domes together, or a combination of vaults and domes, can be used to create varied and interesting forms and interior spaces.

Both domes and vaults should be covered with a second layer of bricks, laid flat in mortar, which increase water protection.

### Walls

The walls that support the roof need to be thick enough to take the outward thrust of the roofs. This thickness therefore depends on the design of the roof and the size of the rooms, but for small domestic construction with rooms no

larger than three or four metres wide, it is common for walls to be about 400 mm thick, and with the added guide that as the roof span gets larger the spring point should lower. Novice builders should follow designs that have taken account of the roof thrust and give the right thickness. With guidance, the builder will learn what can safely be built.

It is also important when building these thick masonry walls that the bricks are laid with care and with respect for a bonding pattern that avoids vertical joints continuing from one course of bricks to the next. The bonding pattern depends on the size of the brick that is being used in the walls, and needs to be worked out for each specific case. There are however some quite standard and basic guidelines which help this choice.

One should distinguish between the construction of roofs that originate from Egyptian vault and dome building, with a span to height ratio greater than 1:5, and the example of vaults influenced by Iranian techniques, which tended to have a much lower span: rise ratio, and needed thicker walls (or ties or the counterthrust of an adjacent roof) to compensate for the forces exerted by the roof.

### Foundations

The foundations can be made with the same bricks used for the walls, provided that precautions are taken to keep these dry. Above all one needs to ensure that rain water flows quickly away from the base of the building.

Where one can afford to, or where there is concern that the ground will be damp, stone or fired brick foundations can be used, or even concrete, but all of these add considerably to the cost and can put the building out of reach of poorer clients. Almost all the Woodless Construction Programme buildings have earth foundations.

### Arches

Openings in the walls are normally made with masonry arches. The shape of the curve can be varied to suit the opening, but it is important to build the arches with care so that each brick is positioned correctly. Poor workmanship can result in cracking. Unlike the roofs, the arch does need a formwork, and this can be made by piling up bricks and shaping the top to the form desired. On large building sites a metal formwork can be economical if there are many openings of the same size to build, as time will be gained. Arches need to have several layers of masonry built up over them before they are strong, and one should not remove the formwork too soon.

### Parapets and water run off

At the perimeter of the roof, the parapets and the infill of the valleys between roof shapes combine to play an important role in controlling the flow of water off the roof to gutters (Fig 10). The builder has the very important job of shaping the final roof so that water flows neither too slowly nor too fast off the roof.

### Flat roofs

Vault and dome roofing can produce flat roofs and upper storey floors, by “flattening out” the valleys between the main roof structure below. This would be expensive and very heavy if done with solid infill material, but by making use of secondary vaults or secondary domes – small struc-



Fig. 10 Smooth curves and large gutters help ensure a good flow of water off the roof.

tures that are built over the main roof valleys – a flatter surface is achieved, which can then be levelled off for use as a floor or usable roof surface. Not only does the flattened roof provide useful space (and with skill and care, the possibility of building more than one storey), it also provides excellent protection to the structure below. Flat roofs need to be built with a gentle slope on them to ensure water run off to the gutters.

### Floors

The floors can be made of any material that one wishes.

### Finishes and renders

Any interior finish can be applied, and the type of service installation can be equally varied, all depending on needs and the means available. Externally, the choice is more restricted, and depends in addition on the local rainfall pattern.

Which render or coating should one use?

Cement plasters do not adhere naturally to earth walls. Although a cement plaster can be used on vertical surfaces, this requires adding either a wire mesh for the cement plaster to adhere to, or providing some other form of “key” that the cement can bond with, such as the use of cement mortar in joints on the outer face of the wall. These options need to be assessed carefully for their economic viability.

Lime and gypsum do make good plasters, but they have a problem with bonding similar to that of cement plasters. Lime wash finishes in interiors are commonly used in, for example, West Africa. Lime when it is available makes a softer, more workable render than cement on its own.

Earth plasters, which may contain additives such as animal manure and straw remnants, have the advantage of bonding well with the earth wall. They can provide a resistant render for several years. Annual maintenance will still usually be necessary.

On the roofs, the use of an earth based plaster is strongly recommended, not only because of the bond with the earth roof, but also because an earth plaster will absorb moisture in its surface during a rainstorm, and then allow this same moisture to evaporate from the roof after the storm is over. Where rainstorms last only a few hours at one time, this effect of drying out is important in protecting the roof. Cement plasters, on the contrary, allow water to penetrate below the surface of the plaster through hair line cracking,

but do not allow the drying out process to take place after the storm, and this can lead to the dangerous accumulation of moisture in the earth roof. As such, the hygroscopic quality of earth based plasters is most important.

Water resistance of earth plasters can be increased by using additives such as vehicle sump oil<sup>12</sup>, or bitumen products and these should be considered where the rainfall is considered high. Equally interesting is the use of natural astringent additives such as tannin coming typically from the bark, leaves or seeds of many trees, and that has a stabilising effect on the earth, sometimes improving water resistance considerably. These processes often form part of local tradition and should be seriously investigated.

### The site and orientation

Because the earth structure must not remain for prolonged periods in a damp condition, choosing a site that will assure good drainage is important. It is surprising how many people will start to build on a site where water will collect, including building in old river beds, sometimes in the misguided belief that climate change has removed the likelihood of flooding. One should also avoid ground that shows signs of swelling and instability, and in preparing to build, one should look for tell tale cracking in existing buildings as a sign that seasonal swelling, typical of black cotton soil, has taken place. If this is so, consider finding another site.

Locating the building on the site is of equal importance, notably in designing and orienting the structure to minimise exposure to the direction of prevailing rains, which in turn reduces the rate of erosion. Care in orientation will also contribute to the climatic performance of the building itself.

### Training

Traditionally builders learnt the skills of vault and dome building through a long process of apprenticeship. This process could last many years.

Introducing vault and dome building techniques into areas where recent changes such as depletion of trees, population increase and increased sedentarisation leading to more permanent building demand, all mean that the time for a long apprenticeship is rarely viable at the beginning of a programme of introduction. There is a need to quickly develop a solid base of skill, so that the local demand can both be generated and satisfied. The long apprenticeship method cannot work at the start of a programme.

In the case of the Woodless Construction Programme, after several years of providing training opportunities directly on building sites, Development Workshop concluded that short specialised training periods interspersed with time available for builders to find work on vault and dome building sites provided a good balance of learning in training and learning by doing. Thus builders coming to these techniques for the first time, but already with experience of earth building, are usually enrolled in an eight week programme composed of three weeks of theory and practice on training structures, and five weeks of closely supervised construction on simple buildings. Builders showing interest in the techniques after this introduction get the opportunity to come back several months later for a further period of

12 This is a less environmentally friendly product but it is often easily and cheaply available, and may as well be used, rather than simply poured away.



Fig. 11 The radial arm showing the placing of bricks in a pendentive, the lower part of the corner of a dome.

training, raising the standard, and consolidating gaps in the knowledge they have retained.

Critical points in training and follow on builder support are (a) developing the practical skills, and (b) understanding the effect of the outward forces exerted by vault and dome roofs and arches, all of which need to be taken into account in the structures and how the bricks should be laid. Builders coming to these techniques from a tradition of flat roofed buildings need to appreciate the difference in the forces exerted by the curved roof. Difficulties occur, paradoxically, more in wall building than in roof building. Learning to build the roofs is a completely new experience for the trainee. The “guides” for dome and vault building help maintain the correct shapes and angles of bricks (Fig 11). For wall building, builders can arrive with “bad” wall building habits that were adequate for flat roofed structures, and these can take time to overcome.

Development Workshop’s approach is to review the technical and pedagogical training content of both beginner and refresher courses at least once a year. The review is important, because despite long experience, there is an ongoing need to respond to difficulties trainees encounter and to make small technical and conceptual adjustments that make the techniques better suited to the locality. Building the entire corner wall of a dome first, before starting the pendentive, is one such recent innovation to simplify the builder’s task.

The majority of builders return for additional training which gives them the chance to bring their skills up to date. Not everyone learns at the same pace, and opportunities for further revision courses are provided. Builders who show real potential are invited to train as team leaders/site managers and for a smaller number, to be trained as trainers, which requires not only evidence of skill in the technique, but also the ability to pass on these skills to colleagues. Training for local technicians and a few architects also needs to take place, in part with a focus on developing a relationship between the builder and the designer, where the latter needs to appreciate the technique and what the builders are capable of constructing.

Training courses are based on a detailed training guide and a specific programme for each level of training. The daily operation of training programmes is carried out by the local builder trainers, and on average a training programme involves between thirty and forty trainees at one time.

Formal training programmes are possible where finance is available. But where the aim is make the vault and dome building technique a method regularly used within the local building vocabulary, this means also developing training opportunities within established vocational institutions, and gradually returning to a form of apprenticeship amongst builders in the community, once sufficient demand has been developed to keep builders in work.

## Aspects requiring further development or improvement

### Skill development in the formal and informal sector

Earth vault and dome building techniques suit construction in both the informal (often lower income) and formal (often public) building sectors. Local “community” builders, however, working to meet the needs of the informal sector, very often do not have the skills to manage construction sites within the formal sector, nor necessarily undertake the full range of building tasks that are typically called for in formal sector projects, and which go beyond the immediate training scope of introducing the basic techniques of earth vault and dome roof building. Where the introduction of the technique is successful, as for example in the case of the Woodless Construction Programme in Niger, public sector demand has tended to deprive the poorer informal sector of trained builders, and has required that the builders, trained initially to meet informal sector requirements, need to receive training in complementary skills to enable them to operate institutionally and practically in the environment of formal contracts and contractors. This suggests (a) that as the introduction of the vault and dome technique begins to develop a market, so too must the need for training evolve to embrace more aspects of the building industry, and (b) that training and apprenticeship need to be sustained within the informal community to meet this demand.

### A greater number of builders to assure competitiveness and quality

The introduction of vault and dome techniques can only be regarded as successful when one achieves a sustained local (or national) demand. This means developing the market through demonstration, training enough builders and building supervisors to satisfy the demand, and making sure that there are masons in sufficient number to provide competitiveness and a choice to the public, and the motivation to offer sensible prices and good quality workmanship. Overall, it implies creating a significant demand in order to interest builders, and assuring that there are sufficient numbers of builders to satisfy this demand. This quite delicate balance is one aspect of introducing innovative techniques that needs in every case to be developed.

### A stronger relationship between the designer and the builder

The nature of structure, forces and limits in earth vault and dome buildings requires that the designer should have a good understanding of (a) how the technology works and what its structural constraints are, and (b) whether and how the builder can actually build what has been designed. This relationship between builder and designer, that often existed traditionally, is now rarely developed, due in part to the characteristics of the many materials used in building.

It implies that future training for designers must not only cover the concepts of vault and dome design and techniques, but also develop a practical understanding of how the building is constructed and in what order.

### 3 Recommendations

---

#### **Constraints and criteria for deciding if woodless construction is suitable**

Careful thought is needed before deciding to build vaults and domes using unstabilized mud bricks. As with any building system, one has to be confident that these techniques stand a real chance of suiting local conditions and matching the needs and aspirations of the people. Certain criteria need to be taken into account, including the lifestyle of the builders and users, the climate, and the resources – material and financial – that are available.

#### **Is the “problem” a building problem?**

What is the “problem” that introducing earth vaults and domes is meant to address, and does woodless construction have a contribution to make towards resolving it?

Woodless construction has for example, a potentially useful role to play where (1) local building systems tend to rely heavily on other resources that are no longer easy to obtain – wood and non local materials – and (2) where earth is an available resource.

#### **Does woodless construction suit the need?**

Although skilled builders can build a large variety of structures, most builders in the first few years will not have these skills nor experience, and supervision skills may be lacking. If these are the case, one should avoid trying to build vaults with spans in excess of 4 metres, and domes in excess of 5 metres. Even these sizes require considerable care and must be accompanied by the correct design of the walls and spring point heights. Avoid using vaults and domes if the skills do not match the space required.

#### **Are the techniques affordable?**

Who is targeted by the introduction of these techniques and will these people be able to afford them?

Low income groups may not be in a position to adopt a new building technique, or not until the skills have developed in their own community to the point where both confidence in the technique and access to potential *free* builders (such as members of the family) is possible.

#### **Will the local population like domes and vaults?**

Vaults and/or domes may already be known forms and be linked with a particular function or image, not necessarily positive. Cost and ease of obtaining materials, for example, are not necessarily the main criteria, and in some part of the Sahel the vault and dome techniques have been adopted because they are regarded as being fashionable, whilst in others there has been little enthusiasm for – say – round domed rooms that may have old fashioned connotations.

Both simple and prestige demonstration buildings give people time to react – favourably or otherwise.

#### **Is the climate suitable?**

It is a common misconception that unstabilized mud brick vaults and domes can be built only in the most arid regions of the world. Correctly designed and built, they work well in wetter climates. However, one should obtain information about the climate and the rainfall pattern. Annual rainfall figures are not on their own useful: it is important to know *how* the rains come: a climate with long periods of gentle

rain will be far more difficult to deal with than a climate which has short but heavy rain storms, even if these are frequent.

**Is earth an available and local material?**

**Check that the materials being proposed are in reality local**

The cost of transporting loose earth or bricks more than one or two kilometres can mean that it is no longer economic, and could justify using an alternative material that requires, for example, smaller volumes to transport. This can be particularly true in urban areas where access to raw materials can be difficult.

**Check that the soil is suitable**

Are earth buildings common in the area? Are they in good condition? Do the local inhabitants regard them with pride? Are they happy to live in them? If the answer is “yes”, it is probable that local soil is suited to earth building.

There are simple field tests (see Boxes 1 and 2) which help determine if the local soil is suitable, but local builders can tell you where they obtain their soil for block-making and whether they add anything to it. This information can be invaluable.

**Box 1**

**Drop test**

No equipment required – medium accuracy.

*Method*

Take soil that has had some water added to it. Squeeze the damp soil into a ball in your hand. Then with your arm straight out at shoulder level, drop the soil ball onto a smooth clean surface at ground level and observe the result:

- if the soil stays in one piece it is too dry: add water and try again;
- if the soil is still in one piece the clay content is too high;
- if the soil breaks into many pieces, it is too wet: leave it to dry a while and try again;
- when the dropped ball breaks into only a few pieces it is close to the optimum water content, and suitable for use.

Continue to use the drop test to check the water content of the soil as it is being used.

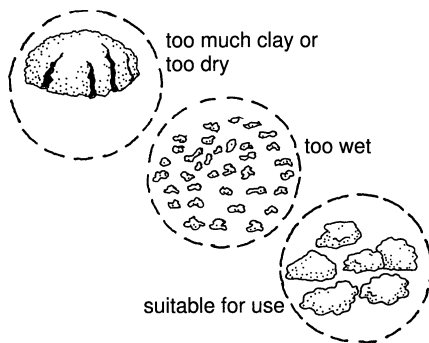

**Is there an available workforce?**

Vault and dome construction is labour intensive: check that builders and labourers are available. In some locations male

**Box 2**

**Roll test**

No equipment – useful indicator.

*Method*

Take enough soil to form a roll about the diameter of your thumb but about 2 or 3 times longer. Wet it slightly until it is still firm but damp. Put the roll in your hand and shape it between thumb and forefinger to form a roll 20 – 25 mm in diameter, and 200 mm long if possible. Place the roll across the palm of your hand. With your thumb gently ease the end of the roll over the edge of your hand.

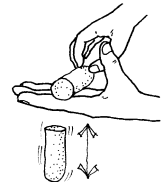

Measure how long the roll can get before it breaks off. Check the length of the first bit that drops off.

- a long roll, 150 mm or more, indicates a lot of clay, and a soil generally unsuitable for load-bearing construction. The soil is likely to crack when drying, and to be susceptible to moisture: a stabiliser will be needed, which could be provided by adding sand. You can try this, and see the difference.
- a medium roll, 80–120 mm, suggests soil normally suitable for building; within this range, the longer ribbon would be better suited to uncompacted mud-bricks, the shorter ribbon better suited to compaction either in a press or in rammed earth;
- a short roll means there is not enough clay to bind the soil, and therefore the soil is unsuitable for load-bearing construction. It requires modification (by adding clay, or by stabilising, or by compaction, etc.) to be acceptable for use

members of the community may have gone away to find work, and it may also not be socially acceptable to train women, although there is no technical reason for not doing so.

**Ownership and building care**

Earth vault and dome buildings require maintenance, and one should consider carefully whether there is a genuine and effective responsibility for maintenance. Typically, school buildings are examples where the state often cannot afford to carry out maintenance work, and at the same time the community does not feel that this is its responsibility. If this is likely to be the situation e.g. an absentee client, or project:

- make sure that money is available for reducing maintenance needs with, for example, durable wall plasters; putting a cement plaster on outside walls.
- put in place a maintenance routine.

**Time and resources**

Introducing a new technique such as vault and dome roofing takes time and great attention to detail. Any project wishing to introduce vault and dome roofing should recognise that builders will need:

- opportunities to receive good training, usually in several repeated sessions;

- ongoing support and follow up, to both check quality and provide an answer to difficulties the builder encounters.

No training at all is better than insufficient training with no ongoing support, where the risks of a builder making a mistake are compounded.

### Equipment

Check that people can obtain a minimum of equipment needed. For producing blocks, one needs only:

- tools for digging;
- simple or multiple hand-moulds that can be made of wood or metal;
- a water container.

For construction work:

- common masonry tools;
- a level;
- a plumb bob;
- for dome-building, a wire or string, or a rotating arm, to determine the angle and position of each brick;
- for vault-building, wire or string to trace the curve of the vault and to stretch guidelines during construction, and a few nails;
- a method of scaffolding for support when working high up;
- spikes to help in laying out (made of sticks or short lengths of reinforcing bar);
- a sack, basket or basin for transporting mortar.

## How to choose the appropriate technical option

### Required material properties

#### The bricks

The locally available soil should have a good even range of coarse and fine grain sizes in it. The roll test (Box 2) should give a sample length greater than 50 mm, and less than 150 mm. Long samples have a risk of being too high in clay content, and bricks are liable to crack. Bricks should be free of cracking, and be uniform in shape. The degree of shrinkage compared to brick mould size should not exceed 5%. The bricks should be regular in shape, and show very little sign of slumping and deformation after moulding. The soil should produce blocks which will withstand a simple test for rupture (see diagram) when dry.

If there are already earth buildings in the area, look and see how they have performed, and talk to local people

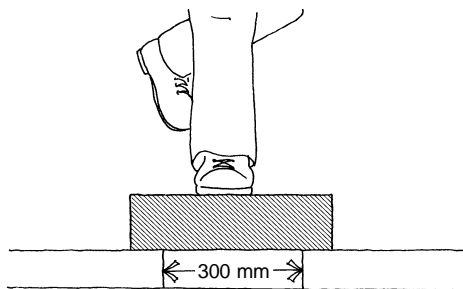

Fig. 12 A small two-roomed house, with one domed room and one vaulted room, provides a good training module.

about the building conditions. If there are (exceptionally) no earth buildings in the locality where one intends to build, find out why – there may be good reasons for not using these sites or soils.

### Which options to choose among the techniques

Woodless construction is not one “standard” building choice, but a number of building options. The use of domes is popular amongst new builders, because the mobile guide makes building easy. Experience shows that vault building requires more supervision until confidence has been gained. In training it is recommended that both types of roofs are used, and that the builder learns to join the two together, to develop skill in using the techniques to solve different building needs (Fig 12). Vaults provide a slightly more vertical wall surface. This is particularly the case where a central vault is placed between two side rooms; the counter-thrust that the roofs of these side rooms provide enables a low profile vault to be built in the middle.

Where the spring point of the dome is at head height (sitting or standing) the shape of the dome can produce an irritating acoustic effect, which can be overcome by lowering the spring point, or by building in hanging baffles in the roof. Metal supports for hangings should be built into the roof structure at the time of laying the bricks.

Flattened roofs are a useful option, but builders learning for the first time will have difficulty mastering the construction of secondary vaults.

### Construction in disaster-prone areas

Special precautions are needed in earthquake areas, including ring beams and ties. Traditionally many buildings in Iran<sup>13</sup> and Afghanistan were built with woodless construction techniques. The danger of wall failure leading to roof collapse is ever present, but this applies as well to traditional flat timber and mud roof buildings in the same region.

Woodless construction should be avoided in flood risk areas, unless one could build well above the flood level.

High rain in cyclones is more likely to be a problem for mud brick vault and dome construction, plus the risk of flooding. On the other hand, woodless construction is very good in high wind areas, and this is a real risk in for example West Africa, where metal sheet roofs are frequently blown off.

13 DW studied the effect of earthquakes on vaults and domes in Iran in the Zarand and Bandar Abbas earthquakes in 1977, and concluded that whilst heavy masonry or mud roofs represent a serious risk in earthquake zones, the key precautions involve strengthening the walls and adding ring beams at the top of walls which greatly reduces the risk of failure in the roof.

## How to introduce the construction technique

### Consider all the options and remain flexible

Vault and dome roofs can be built with a variety of materials, including earth blocks, cement or lime stabilised compressed earth blocks, fired bricks and stone. The roofs can be constructed with or without formwork. The finishes can vary according to (a) climate, (b) the client's budget, and (c) resources. Woodless construction represents one option for building in a given context, but it may not be the best one. If it does on the face of it seem to be the most realistic and viable option, here are some guidelines for starting.

### Build a small demonstration

Where conditions seem right, one should start by building a small demonstration unit so that one can discuss and obtain local reactions, and assess how these techniques work in the local context. A demonstration allows local builders to participate and explain the techniques to other members of the community. In all cases, make sure that the building is needed, as a neglected building will not be a good demonstration.

### Take your time

Although there is frequent pressure to produce quick results, the worst mistakes come from trying to go too fast. One should take one's time, and recognise that introducing a new building technology must be considered as a long term action. Losing a few months makes no difference if the result is to get the product and the process right.

### Avoid building too big or too much

Pressure often comes from clients to build large structures – for example, there are frequent requests for classrooms with woodless construction – which stretch the technical capacity of newly trained builders (and equally important, can stretch the capacity of the users to maintain the finished building). The builder will often need courage to resist the pressure to build beyond his limits, and this is most difficult where the client introduces a financial incentive to do so. A promoter of woodless construction should give the builders clear guidelines on what they can realistically build, and should support them in their negotiation with clients, if need be with written material.

### Make the techniques respond to local needs and expectations

The original techniques as brought into the Sahel in the Woodless Construction Programme have needed considerable modification to suit the new context, to make them easier to learn, and to respond to local needs. These changes will be outlined in Chapter 4. However, in introducing woodless construction, one can as a general rule highlight the following aspects.

### Offer flexible choice of space

The builders are introduced to woodless construction as a choice of roofing systems that can cover different sized spaces. A potential client can choose what sort and form of building is desired and woodless construction can and should respond to these differences in preference. It helps to provide a variety of plans, but it is important that these respect the limitations of the builder.

### Suggest different levels of owner contribution

Woodless construction can be competitive in price against earth walled buildings with good quality timber roofs, and considerably more so with building systems using a larger proportion of non local materials. But even so, not everyone can afford to pay for the materials, labour and the skills of masons. But because woodless construction already uses local labour and materials, clients can in effect decide to vary the level of their "in kind" contribution, for example by making the bricks themselves, and supplying the unskilled labour. This means that woodless construction can become a very cheap option for a family wishing to build using their own time.

### Encourage variety in decoration

Internally and externally, the appearance of the building is essentially up to the builder and owner. In particular, although the roof parapet plays an important role in water run off management, it is also an important decorative feature, and allows the builder to express himself and reflect local styles. In some places people tend to largely hide the curved roof shapes behind flatter parapets, whilst elsewhere these forms are more clearly expressed. Pride in the work helps contribute to maintaining good quality in the builders work, and for the owner, the same contributes to encouraging care for the building.

### Propose options for reducing weathering

Woodless construction can be protected with cheap earth plasters, or, where it can be afforded, can have more costly wall plasters using cement.

### Inform clients about the wide choice in the quality of finishings

The quality of internal finishings can be varied according to the owner's means, and can range from very simple to very high quality.

### Provide training

Although the gradual gaining of experience on building sites is essential, specific and repeated training opportunities are important when the technique is being introduced. They allow the builder to practice and make mistakes which can be taken down without causing any embarrassment to the trainee. The pressure of a real building site frequently imposes that small errors do not get corrected, and this detracts from the learning process.

Training should be mobile, meaning that training takes place in different localities, with local participants, where the training can and has to take into account local realities about the climate, the way people already build, the size of the bricks, or the availability of water, all of which are factors to which woodless construction needs to adapt.

Trainee builders should be selected in pairs, with the aim that they learn to work together, as this is important in roof building. One builder on his own will not be able to build well, and in the community one single builder is unlikely to feel and express the same confidence to build.

Where possible, it also helps to encourage builders to introduce their own labourers on training and building sites. These opportunities prepare the labourer to be trained as a builder and in the long run, a return to apprenticeship will contribute to sustaining the techniques in the community.

## 4 Case study: woodless construction in the Sahel

In 1980 an integrated rural development project, *Projet Tapis Vert* (PTV), in Niger became aware of local problems in obtaining organic materials, notably wood, for traditional housing. This problem was and is part of the larger problem of desertification – natural resources becoming increasingly scarce; the people who depend on them aggravating the problem by over-consumption forcing them to search for alternatives.

Development Workshop was invited by the PTV to introduce domes and vaults as an alternative to the use of wood and branches in flat roof building. An initial training and demonstration project was organised at Chikal, Niger. Peter Tunley, then working for PTV, took part in this initial project and continued to build with the vault and dome techniques. Quickly it was clear that changes were needed to make the techniques easier to learn and to suit the climate. Tunley's discussions with Development Workshop and others helped start the process of developing and adapting the techniques to suit the Sahel context.

After the initial work building with the PTV, support came next from the WWF-sponsored *Air Ténéré Project* (ATP), in northern Niger, where infrastructure was needed. This project provided an opportunity to build a wide range of demonstration buildings, from small structures to large and prestigious offices. These helped consolidate the reputation of the building techniques but there were few opportunities for training, other than "on-the-job"<sup>14</sup>. It was not until the 90's that it became possible with support from the Danish government and IUCN<sup>15</sup> for Development Workshop to launch a programme of dedicated training courses for local builders, the main purpose of which was not the construction of buildings, but instead the development of builders' skills.

Sixteen years after the introduction of these techniques, masons from Mauritania, Senegal, Mali, Burkina Faso, Niger and Chad have received training. Development Workshop co-ordinates woodless construction training and promotion activities in Niger, Mali and Burkina Faso, and the demand for vault and dome building currently tends to be greater than the supply of trained builders. The techniques have shown themselves to be adaptable to a variety of needs and are an accepted method of construction in the region, in both the informal and formal building sector. Especially important, the techniques have over the past ten years been adopted into the local building "vocabulary", with local builders trained in the techniques using them spontaneously, both for their own homes, and in response to growing demand from individuals and organisations, including state bodies.

This chapter seeks to show how, and to what extent, this assimilation of a new method of building has been, and continues to be, brought about. It also seeks to draw lessons from which other areas facing similar or parallel problems can learn.

## Background

### The geographical context of the Sahel

The Sahel is the semi arid region immediately to the south of the Sahara stretching from Mauritania to Chad, characterised by low rainfall ranging from less than 100 mm p.a. in the north up to 800 mm or more in the south. Rain, when it comes, is usually in the form of short heavy storms – 80 to 100 mm in one storm is not unusual – and mainly during the months of June to October. This characteristic of infrequent, but very heavy storms is a more significant factor than the annual rainfall figure.

Periods of drought in the past 25 years have contributed directly and indirectly to a reduction in the availability of trees and organic material traditionally used in building, both for light supporting structures and – more crucially – as timber for flat roofed earth brick houses.

Temperatures can rise to over 40°C in the periods before and after the rainy season, and drop at night to near freezing in the north, although these extremes of temperature are less marked in the slightly more humid south. Overall, ventilation plays an important part in achieving comfort inside buildings, and so too does good insulation. The winter period in December and January can be uncomfortably cold in the desert regions, and for the population cold can be more of a problem than heat.

### Socio-economic context

The north of the region is principally inhabited by Tuareg nomads, whilst in the centre and south there is a diversity of ethnic groups and activities: herding in the north gives way to crop production in the south, where the population is much more sedentary. The drought years contributed to increasing the sedentarisation of the nomads, and at the same time there has been a general migration towards the larger towns. Overall population growth averages 2.5 to 3.5% per annum but urban growth in Niger, for example, is nearer 7%. All of these factors contribute to added pressure on substantial organic building resources, notably in the periphery of towns where demand is greatest.

The financial position of most people is very poor, and for many families disposable cash is virtually non-existent. In this socio-economic context, many activities are undertaken in a spirit of mutual help, especially in rural communities. It is therefore at times difficult to place a monetary value on a product achieved thanks to non-remunerated participation and the use of materials which are available at no financial cost, but often at the price of considerable effort and environmental damage.

### Target groups concerned by the problem

In this overall context, woodless construction techniques are therefore relevant to the following target groups:

- people who habitually made use of wood or branches in meeting their shelter needs, and who are now finding it difficult to obtain these materials, having to travel greater and greater distances to find what used to be a free, local resource;

<sup>14</sup> The ATP, World Vision and the US Peace Corps all sponsored intermittent training opportunities in the period from 1987 to 1992.

<sup>15</sup> The World Conservation Union based in Gland, Switzerland.

- people who still use wood, and have not yet encountered major difficulties, but where the rate of consumption will deplete resources in the foreseeable future;
- people who can no longer afford to use non local materials, in part as a result of the devaluation of the regional currency, and who are (re)turning to wood roof building as an alternative;
- the state and agencies providing public facilities, where both the example and the saving resulting from not using wood stand as an example to others.

In terms of training, woodless construction primarily targets local builders, who are the key agents in introducing the techniques.

### Building practices – traditional and modern

In the south of the region people have for centuries lived in buildings where the walls were made of mud and the roof of mud and wood – beams and branches – or thatched in zones of higher rainfall. In Niger and Burkina Faso, granaries, and previously houses, were also built entirely in mud, using a form of coil construction similar to certain types of pottery. In areas where seasonal migration was common in the past, the process of sedentarisation had led to the use of more permanent shelters. In the northern areas, light structures (tents and round thatched grass-walled shelters) have been increasingly superseded by houses. In general these too have walls built from sun-dried earth bricks and roofs of timber beams, rafters and laths covered with mats and earth. Most traditional buildings consume significant quantities of organic materials, including grasses, straw, branches and tree trunks. Most also use earth as a building material. In many areas traditional practices and use of materials has not changed, although the species of tree used has changed significantly and obtaining the materials has become much more difficult.

In the cities, and where the resources are available, more expensive materials may be used, including sand cement blocks for walls, some use of fired bricks and stone, and rarer examples of stabilised earth blocks. Roofs in the modern sector are either covered with corrugated sheets (iron or aluminium), or reinforced concrete, and both where available. Clay or more recently sand cement tiles with a wooden framework are also found. For the majority, non local modern products remain unaffordable.

## Earth building and earth roof building in the area

### Earth walls

Earth building for walls remains the predominant method of building, and earth blocks are manufactured on the outskirts of almost all settlements. The size of blocks varies from settlement to settlement, and even in one location. Walls are normally plastered with an earth based plaster, to which additives including manure and straw are normally added. Some places have a reputation for skilled production of wall plasters, including using local tannic additives, and the durability of these can be excellent.

Local builders are responsible for much of the building work, but the quality of contemporary mud wall brick laying is often poor, with little attention paid to correct bonding or to filling joints.

### Earth roof construction

The main method is to lay timber beams across the width of the room. Smaller sticks and branches are laid between these, and matting placed over the sticks. Earth is then compacted on top of the matting. The gentle slope of the roof provides for rain water run off, although with time decay of the timber and added layers of earth mean that the roof may sag in the middle. When this happens, water soaks into the roof, increasing its weight and it is not uncommon for flat roofs to collapse under the added weight, and usually without any warning.

Traditional Hausa<sup>16</sup> roofs in Niger replaced beams with a curved framework of sticks encased in mud, forming the “ribs” of domes. Laths were placed between these ribs and a coating of mud covered over this supporting structure. A very few examples of vaults built with these techniques also existed.

As finding long pieces of wood has become more difficult, one option for building sizeable rooms has been to place a central pillar in the room, on which shorter beams could rest. With the decline in the availability of timber beams and the increase in their cost, rooms have also become narrower. Builders using woodless construction appreciate the possibility of spanning larger spaces.

Used in the past for houses as well, the building of grain stores with a thin shell of mud continues to be common. These granaries are usually round in shape, although small rectangular structures are also possible.

## Choice of technical options, and criteria affecting this choice

When invited to demonstrate earth vault and dome construction in Niger in 1980, Development Workshop initially chose to use vault and dome techniques originating in Egypt. Compared to other methods, and particularly those common in Iran, these had the advantage of being relatively easy to learn:

- the Egyptian dome building method makes use of a radial guide – usually a piece of string – to help builders find the correct position and angle of each brick;
- the shape and high span to height ratio (around 60%) of the Nubian vault makes it both strong and capable of being built on relatively thin walls (compared to the requirements of the lower profile Iranian vaults in terms of both skill and understanding of the supporting structure).

Furthermore, these techniques could use hand moulded earth bricks, earth mortar and traditional plasters – all familiar local resources – and needed a minimum of special equipment.

The good climatic performance of earth vaults and domes was also an important criteria.

<sup>16</sup> Name of an ethnically diverse, but culturally fairly homogenous African people of north-western Nigeria and south-western Niger. The Hausa language has become a common language for millions of non-Hausa West Africans.

## How people are taught

### Deficiencies of “on-the-job” training

Until 1987, the introduction of these vault and dome building techniques was undertaken in Niger in the context of various programmes linked to rural development and to the management and conservation of local resources. The primary objective was to build rather than to train. Ad hoc “training” on-the-job, meant builders of widely varying experience and qualifications working on the construction of one or more buildings. Although this provided opportunities to learn, not everyone could be exposed to the same experience. For example, more skilled builders were naturally assigned to the more complex tasks.

Such on-the-job training, although by no means totally unsuccessful<sup>17</sup>, did not however allow all the masons involved to be trained in all stages of the building process – from laying out to finishings. Normal site pressures meant that there was no opportunity for repeating the same operation several times (laying out, choosing a brick pattern, building the vault or dome etc.). The builders therefore typically emerged with an incomplete view of the *whole* process, and this was a serious deficiency, since knowing how to build a vault or a dome without also knowing how to build adequate foundations and strong walls is potentially dangerous.

### Dedicated builders’ training programmes

Recognising the deficiency of on-the-job learning, from 1987 onwards opportunities were sought to run dedicated training, as opposed to primarily construction, programmes. These included exercises to practise various construction stages on structures that are built, taken down, and rebuilt as often as necessary, and opportunities to learn the principles behind the structure of the buildings. The improvement in the overall understanding of the techniques amongst builders and their subsequently better quality work on “real” construction sites, confirmed that a dedicated programme of training of builders and of local trainers was necessary if the vault and dome techniques were to achieve wider use. With this in mind, from 1992 onwards funds have been obtained to provide training courses on a regular basis in Niger, Mali and Burkina for builders and technicians with different levels of experience.

### Builders new to woodless construction techniques

Trainees participate in an eight week course, composed of:

- two weeks theory and practice on training structures (Figs 13 and 14);
- five weeks learning on the construction of small buildings from laying out through to completing the structure;
- one week theory and practice on aspects of finishing the roof, placing gutters, and selecting plasters.

Between 32 and 40 builders are trained on each course. Trainees work in groups of four, under the responsibility of an assistant trainer. Each team is responsible for its own building, constructed for a real client in the community who contributes labour and materials. The course is run by a head trainer, responsible for theoretical teaching inputs,



Fig. 13 A local trainer giving a theory session for laying out a rectangle.



Fig. 14 Trainees practising vault building on special training structures.

organising demonstration work and supervising the quality of the buildings.

### Refresher courses

Three week refresher courses are organised for builders who have already participated in a previous course. These follow the same course structure as the three weeks of practice and theory, but do not involve work on complete buildings, (although invariably trainees go on to work on vault and dome construction sites and receive supervision). More attention is also paid to site management and the presentation of woodless construction.

### Training of trainers

Two week courses are organised for training trainers drawn from amongst the most experienced builders. Depending on individual skills, they are trained either to the level of head trainers or to that of assistant trainers and site supervisors.

### Technician training

Opportunities are provided for technicians to participate in builder training programmes, since “hands on” practical experience is an essential part of understanding these techniques. Additional training, often in the form of individual teaching, is provided for design and understanding of the structure. These training sessions always have to be organised on a specific basis in the light of the time participants have available, which is often limited.

### Technical documentation

Although in training, manuals have never been used to help learn how to build, Development Workshop has found that

<sup>17</sup> For example, a number of local masons from Iférouane, northern Niger, working over several years on ATP infrastructures, became highly competent in using the techniques and have gone on to become trainers in their own right.

they are useful *afterwards* as a reference to remind trained builders what they have been taught. A first Guide<sup>18</sup> was produced by Development Workshop in 1990, and dealt with building rectangular and round domed buildings, and rectangular vaulted rooms. This used photographs and drawings, with minimum explanatory texts under each drawing, in an effort to overcome difficulties of literacy and language. (There is a multitude of local languages – trainees from as many as five different language groups, with no common language, have taken part in the same training course using interpreters.)

To support the training process, a Trainers' Guide<sup>19</sup> was produced in 1993, and revised annually, to incorporate lessons of the past year. The guide constitutes the basis of the training programmes and their curriculum. It includes how the teaching should be done, what demonstration or practice structures need to be prepared or built in advance of the training session, and which key points need to be particularly stressed. It also includes revision sheets to be used for the final stages of the course.

Trainee builders in turn receive a shorter "aide-mémoire" document<sup>20</sup>, which summarises each item they have been taught, for their own use.

For use both in training and in awareness-raising activities to a broader audience, the training teams have a 20 minute video<sup>21</sup> explaining the objectives of woodless construction, a set of slides illustrating key technical points, and they are encouraged to use simple models for some of the explanations (e.g. miniature, scale bricks to illustrate bonding patterns).

## What modifications have been made to the original technologies?

### Continuing change

Adapting the woodless construction techniques to the local context has been an ongoing process, fed by observation of difficulties encountered and local building practices and needs, and has focused on two main aspects:

- making the techniques easier to learn and use, and thus safer;
- making the techniques respond to local needs and expectations.

The latter often reflect very local conditions and habits, and are not necessarily promoted throughout the Sahel. The programme has also had to recognise that "good" building practice must be compatible with pragmatic building methods that builders are likely to continue to use after training. The following examples illustrate some of the changes that have evolved.

### Making woodless construction easier to learn and use

#### Using local brick sizes and laying methods

During the 1980's brick dimensions and bonding patterns were determined by precisely dimensioned plans using bricks laid as headers and stretchers and an often complex bonding pattern that acted as a brake on the assimilation of

the techniques. To simplify building, and following common local practice, brick laying has in recent years been changed to "headers only" for the majority of small buildings. This gave good results and remains popular today. A further step was to eliminate the need for cutting bricks to fit given measurements, which could result in poor bonding along a wall. The Woodless Construction Programme has therefore adopted using the *brick itself* as the unit of measurement. This enables the laying out of the buildings to be based firstly on approximate metric dimensions and then precisely on site in terms of an exact number of bricks and joints, an approach that takes account of local variations in brick sizes.

#### The brick saw

Using the brick as a unit of measurement does however create potential conflict with inserting ready made joinery. An answer has been to build the width of openings smaller than required, and then to use a wire "mud brick saw" to trim the opening to the desired size. This avoids making unsafe adjustments to the bonding pattern in the wall.

#### Drawing the vault

Whilst Nubian vaults were drawn by eye or with a template, Sahelian builders found skilled drawing by eye difficult to learn, and the use of a template unwieldy and impractical. A method has therefore been developed using wires and based on the subdivision of any given vault span into thirds. Based on this one third length, three equal length wires are joined at a common point. Two nails are placed at spring point level into the end walls of vaulted rooms at one and two third intervals, to which the two of the wires are attached (*Fig 15*). The builder can quickly and accurately draw the curve of the vault. The vault shape is not only close to the catenary of the Nubian vaults, but in addition has a more accentuated curve that compensates for the loading over the sides of vault produced by infilling the valleys in the roof.

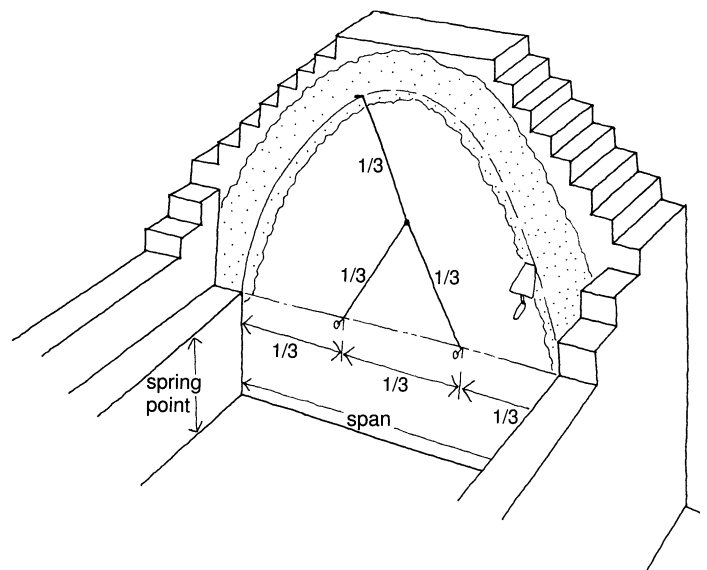

Fig. 15 Drawing the vault on the end wall with the help of wires.

18 Development Workshop, "Toitures sans bois: Guide pratique", with funding from the IUCN Air Ténééré project based in Iférouane.

19 Development Workshop, "Guide des formateurs".

20 Development Workshop, "Aide-mémoire aux maçons", 1998.

21 Development Workshop, "La Construction Sans Bois", produced by Annick Turner.

Fig. 16  
Guiding strings follow the alignment of the vault and help the builder keep a good vault shape.

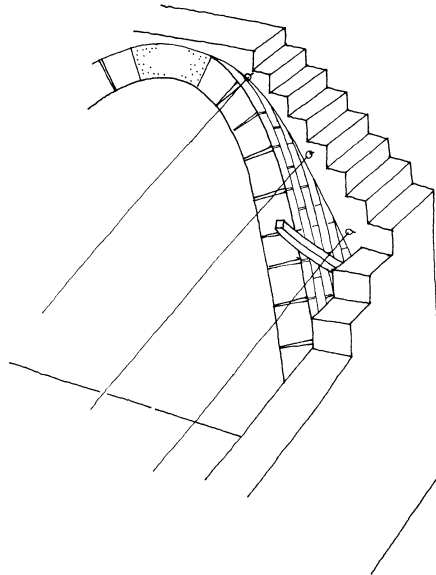

### Keeping the vault alignment right

Unlike Nubian vaults usually built out from one end wall, to help the Sahel builders keep a straight alignment, an early innovation has been the practice of starting a vault simultaneously from both ends of the room. Thus guiding strings could be stretched from one end to the other just above the bricks that were to be laid (Fig. 16). The builder checks that the progressive courses of the vault built out from the end wall follow the alignment of the strings. At each stage, the builder is also encouraged to place a string across the face of the vault, a practice which helps check that the bricks are correctly laid.

### Improving accuracy in the lower part of the vault

Despite the strings, many builders found it difficult to keep the right curve in the lower part of the vault, leading to a much weaker vault form. To overcome this, Development Workshop changed the vault building system in late 97, so that the builder now builds up the supporting wall with large bricks, progressively stepped out to the interior of the vaulted room (Fig. 17). The steps follow the curve of the vault. Actual vault bricks start to be laid about one third of the way up the height of the vault. Controlling the alignment of the stepped out bricks is both easy and fast, and builders unanimously prefer this new technique.

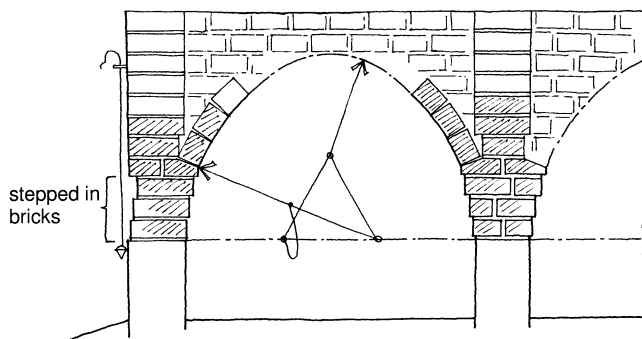

Fig. 17 Stepped in walls make the lower part of the vault easy to build.

### Reshaping the Egyptian dome

The hemispheric domes achieved by using a wire or string attached to a central pole produce a shape with considerable outwards thrust in the lower part of the structure. Ad-

justing the dome to a steeper shape helps reduce this thrust. This has been achieved by introducing a factor of displacement at the rotating base of the radial arm that is used for positioning each brick in the dome. Displacement is usually by one third of the dome's radius (Fig. 9). This gives a steeper curve to the profile of the dome, reduces outward thrust, and enables the dome to have a spring point lower down than a hemispherical dome whilst still achieving the same room height. The result is stronger and requires less wall structure, but the echo of hemispherical domes is also reduced. An adjustable metal guide is given to the masons on completion of their training.

### Introducing eccentric roofs

With the same aim of reducing the spring point level and thus outward force on outside supporting walls, whilst gaining height on the opposite "interior" wall, "eccentricity" has been introduced as an option where the counterthrust of an adjacent roof permits (Fig. 18). The resulting rooms have more vertical wall against which furniture can be placed, and creating openings between adjacent rooms is easier. Eccentric or off-centred vaults and domes can only be built where two roof structures provide an opposing thrust.

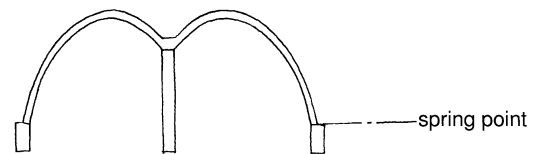

Fig. 18 "Eccentric" or off-centred vaults give more vertical wall space. Here adjoining rooms provide the necessary counterthrust for the same spring point.

### Improving rainwater run off

Compared to the angular shapes of many Egyptian vault and dome roofs, the rains of the Sahel require that water can flow smoothly off the roof. To this end, in the Woodless Construction Programme much emphasis is placed on achieving smooth gentle curves in the valleys between the roofs, that need to be angled to avoid water flowing too fast – causing erosion – or too slowly, causing infiltration (Fig. 10). Wide open gutters are used that cannot easily be blocked.

### Responding to local needs and expectations

Whilst technical changes and new teaching ideas help the builders master woodless construction techniques quickly and help them learn to be flexible with their potential, changes to the form or appearance of the buildings makes assimilation by the population easier. These changes have implied that whilst the techniques remain essentially the same, their application can and should change to suit local needs.

### Flat roofs on vaults and domes

When introduced to Mali, woodless construction aroused strong local interest in the face of increasing difficulty in finding organic materials or the money to pay for non-local alternatives. Many people nevertheless wanted flat roofs, where they could sit and sleep outside during the hot season. As a result in subsequent training, the construction of flat roof terraces with vaults and domes was demonstrated,

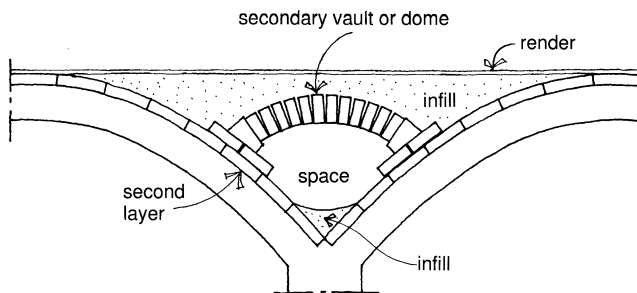

Fig. 19 Secondary vaults and domes (shown here) reduce the volume of in-fill required to create flat roofs.

using secondary vaults and domes to bridge over the “valleys” between the main roof vaults or domes (Fig. 19). The much smaller dips in the roof that remain are filled in with earth. Combined with the use of eccentric domes and vaults these can further reduce the need for infill in the roof, an otherwise expensive item.

#### **Reduced wall thickness**

Woodless construction is mainly about changing the way that people build roofs, but how much material goes into walls is also a concern. In northern Niger, the traditional branch and straw shelter – the *tatagham* built and used by women in local settlements – was also becoming hard to build because of difficulty in obtaining materials. A 200 mm thin walled domed structure was proposed as a replacement. Similar reductions in wall thickness for rectangular structures has also been introduced using alcoves, which – without reducing the strength of the wall – reduce the number of bricks needed and provide useful space.

#### **Replacing existing timber roofs with vaults and domes**

In many parts of the Sahel, existing earth buildings already have thick masonry walls. As well as training for constructing new buildings with woodless construction, the Woodless Construction Programme has also demonstrated the potential for re-roofing existing wood roofed buildings with vaults and domes, provided of course that the walls are sufficiently strong. One particularly successful example of this was re-building the roof of an existing mosque, the wooden roof of which had rotted; this proved a highly popular and “visible” example to the local population.

## **What the impact has been**

### **The work of the builders**

Across the region, woodless construction has been taught to some 600 builders in the past five years. In an average year, about 60% of these masons are actively involved in woodless construction, through work on building sites, and in training activities. Woodless construction therefore represents a significant activity for many builders, even though a very high proportion will spend five months of the year also looking after their crops in the rainy season.

However, building work that comes to them in the villages is often unpredictable, and depends on factors such as the harvest. In a poor year few people will build. But the development of woodless construction in the formal building sector is both giving work and income to trained builders on a steadier basis: a good woodless construction builder can count on getting work and using his skills.

The drawback for the villagers is that the formal sector – and the training programmes – take the best builders away from home, and deprives the community of their skills. Many builders do find time to return to their homes and build for themselves, and this in turn acts to promote the techniques locally. Much as woodless construction is important in bringing skills and work to rural builders, it has been equally important in restoring pride in one’s work. For the vast majority of woodless construction builders, these techniques are regarded with respect and with profound belief in their usefulness to the region.

### **The clients**

Although the Woodless Construction Programme had visited over 600 sites by early 1997, after 18 years a comprehensive list of woodless construction buildings no longer exists, since there are many more buildings being constructed spontaneously that have not yet been visited from eastern Chad to the Atlantic coast of Mauritania. In 1996 a mission to Gao in the north east of Mali found seventy buildings that had not been seen before, built thanks to training that had taken place 8 years earlier. The total number of woodless construction buildings is now probably over 800. In October 1997, there was a waiting list of over 400 buildings in Niger alone, and a smaller but growing number of buildings and requests in Mali and Burkina Faso. The number of buildings per year is increasing steadily.

Owners range from owner/builders in the villages through to government clients, and their buildings are equally varied, from small one roomed round houses to large hospital complexes. For almost all users, it takes one or more years for individuals to be satisfied that these roofing techniques work, although in a recent new introduction in Burkina Faso there was 100% spontaneous replication in the first year, due to the enthusiasm of the builders. Demonstration buildings for more adventurous clients therefore play an important role in developing confidence.

Most occupants mention climatic comfort and the size of rooms as being the main advantages. For wealthier owners, the low cost is often a reason for choosing woodless construction, as well as a significant prestige factor. For poorer users, faced with increasing difficulties in finding good wood for roof building, the advantage of woodless construction is that one can make the bricks oneself, and achieve a durable and comfortable building, although they are at times discouraged by the large number of bricks that need to be made. And although a woodless construction house is more expensive than a similar building covered with poor quality wood, people know that it will last much longer. Villagers in a recent region wide programme for building cereal banks in Niger, when choosing whether to build a grain store with a flat timber roof or one using woodless construction, invariably chose woodless construction because they can provide the materials more easily and they have confidence in the product.

Where users need more encouragement, as with almost all other types of building in the Sahel, is the need to undertake the small amount of annual maintenance necessary to keep woodless construction in good condition, and the Woodless Construction Programme devotes time to encouraging owners to care for their property.

### The buildings and their performance

The main public concern is resistance to rain – unjustifiably. Rain is not a problem, provided that it does not continue for a very prolonged period. In 1994, rainfall in the Sahel exceeded the past 20 year average by 30%: a regional survey showed that less than 1% of woodless construction buildings had problems of rain damage on the roof, and that these were invariably caused by poor infilling in the roof valleys. A slightly greater number of buildings had problems that came from poor choice of site, where there was insufficient drainage at ground level. Meanwhile, in Niger that same year at least 18,000 wood-roofed houses collapsed, leaving 120,000 homeless.

Maintenance needs are determined by weathering from erosion caused by rain. In the Sahel, rain storms come with great violence for short periods, and invariably from the east: these are therefore the walls that need protection, and this is achieved by good orientation to minimise the exposed facades and good roof design, to minimise unnecessarily exposed roof profiles. Good wall renders, planting protective trees and careful site planning can all help reduce the effect of driving rain.

The buildings provide good thermal properties, because their thermal mass reduces the interior differences between hot and cold periods in the day. But in reality where overall temperatures are very high, the buildings stabilise but do not reduce average temperatures. At this point creating cross ventilation will contribute much more to interior comfort, and Development Workshop devotes effort to ensuring that woodless construction buildings provide a good example, not least because ventilation reduces health risks such as meningitis. For the local population, thermal protection in the cold season is more important, and the buildings work well.

The oldest woodless construction building in the Sahel was built in 1980, and is used today, having had only occasional maintenance. Annual maintenance is necessary, to check and if need be repair plasters on the roof and on the walls, neither of which is expensive but requires being thought about – and many users tend to neglect their buildings.

Woodless construction if built following the rules taught in training poses no structural problems. But where masons neglect some of the basic rules, such as building up the external wall behind pendentives or side walls against vaults, usually because of laziness, these errors can lead to weakness in the structure.

## 5 Ecological and economic comparison with other buildings

Putting a realistic price on the cost of buildings in the Sahel is difficult, because real costs range from construction with collected materials and contributed labour through to construction with all items paid. The table below<sup>22</sup> based on figures in 1995 show the difference between the main types of construction in the private sector. Prices have been destabilised by devaluation in 1994, but they do not change the overall picture. Woodless construction compares favourably with mud walled buildings with wood and earth roofs, but this depends on two bases for comparison:

- if good wood – which is expensive and hard to obtain but which *should* be durable – is used, woodless construction is cheaper;
- if poor quality wood is used (and this is increasingly the case) i.e. wood which has a very poor durability, as little as two years, woodless construction is more expensive to build, but will last many years longer.

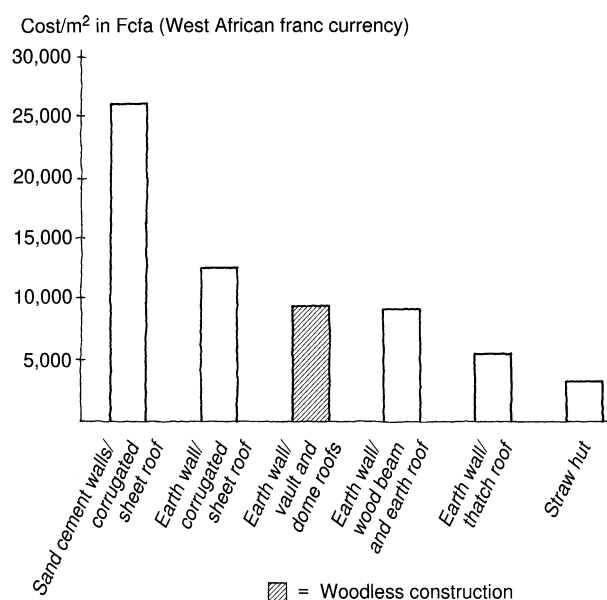

What the table does *not* show is the increasing “monetisation” of the building process, where the cement building represents almost 100% paid material, and in most instances, paid labour, against the thatched hut, which can be achieved entirely by unpaid collective labour. The use of non-local materials is constantly increasing in cost, to the benefit of woodless construction, whilst the increasing scarcity of wood makes it harder for people to build with what used to be collected materials.

A comparison in the use of organic materials shows that woodless construction represents less than 1% organic material in cost, against 30% of the cost in a reasonable quality earth walled and wood/earth roofed house, and 90% organic materials for the thatched hut. At the other end of the scale, woodless construction uses 100% local resources, against an average of 60% local resources for the wood roofed house (since the wood has to come from increas-

22 Figures and the table developed by Marie Line Uhde, on behalf of Development Workshop, in CIDA-sponsored research reports.

ingly further away), and against an average of 45% local resources for the sand cement block and corrugated sheet roofed house.

Equally important, when comparing a wood/earth roofed house with a woodless construction roof, a 20 m<sup>2</sup> dwelling represents an *ecological and environmental saving* in wood of at least 60 linear metres of timber beam and 12 m<sup>3</sup> of battens placed between the beams. Considered in terms of annual increase in population and building demand, this represents a huge number of trees that need to be saved.

Although quantities per square metre do vary depending on design, the table below shows average figures per m<sup>2</sup> for a 30 m<sup>2</sup> building constructed by trainee builders. The speed of construction improves with skill, and this lowers the cost, and one should bear in mind that the choice of quality of finishings can vary widely and for this reason they are not included in these calculations. In every locality one has to determine the tariffs for labour and materials, and for the owner/builder, these may not be accounted in terms of money, but still represent time and effort.

*Indicative quantities for a 30 m<sup>2</sup> building with two rooms covered by a dome and a vault.*

Item	Unit	Quantity/ m <sup>2</sup>	Total in 30 m <sup>2</sup> building
Wall bricks: the size will affect quantities	<i>Either</i> 380 × 240 × 110 mm	116 <sup>a</sup>	3,480
	<i>Or</i> 400 × 200 × 120 mm	130 <sup>a</sup>	3,900
Roof bricks	200 × 150 × 60 mm	191	5,730
Loose earth	Cart loads (about the same as four barrow loads)	3.5 loads	105
Animal manure in plasters	Wheel barrow loads	0.15	4.5
Water	Barrels	2.75	82.5
Trained masons	Usually a team of two or four	3 mason days	90 mason days <i>on a site where the masons have been through starter training</i>
Labour	Roughly one labourer per mason	3 labour days	90 labour days

*a: more bricks will be needed in deep foundations*

## A final observation

The intention of this document, and of the case study included in it, is certainly – but not solely – to briefly describe a technique for building with materials (earth) and basic skills (earth brick production and construction) which are accessible to a large population of largely non-monetarised people. At the same time woodless construction is as much a *process* as a set of techniques. For such techniques, however apparently “appropriate”, need to be introduced in a manner which is in many ways more akin to “listening and responding” than to “teaching”. This process is both slow, and subject to many unforeseen conditions – bad harvests, poor rains, currency fluctuations and more besides – all contributing to the way in which the local population perceive and then decide to apply an innovative technology. Eighteen years of adaptation, training and promotion in Niger, and more recently in neighbouring countries, show that with patience these obstacles can be accommodated and surmounted.

### Development Workshop

Development Workshop (DW) is a non-profit organisation founded in 1973 to work on improving living conditions for the poor in the less developed communities of the world. DW's primary concerns are with shelter and settlement, and urban, rural and institutional development. A central theme is the development of skills within the community to enable all stakeholders to participate in the improvement of their environment and the resolution of problems, and wherever possible making use of existing and traditional skills and resources to meet new requirements. DW works in Africa, Asia and the Pacific, and notably has a long term involvement in Angola and the Sahel. DW is also actively involved in education relating to development issues in the north.

Development Workshop Tel +33 5 63 95 82 34  
B.P. 13 Fax +33 5 63 95 82 42  
82110 Lauzerte, France  
E-mail Devworks.France@Wanadoo.fr

## Bibliography

---

- Andersson L-A., L. Arnsby, B. Johansson, C. Pering,  
and J. Åstrand  
1986 *A Solution to Rural Housing Projects*, SADEL,  
Lund.
- CRATerre  
1991 *Earth Building Materials and Techniques: Select  
Bibliography*, Gate/GTZ, Eschborn.
- Development Workshop  
1998 *Woodless Construction Trainers' Manual*, Develop-  
ment Workshop, Lauzerte, revised edition.
- Doat, P. et al. (CRATerre)  
1990 *Building with earth*, The mud village society, New  
Delhi, India. (Translated from *Construire en Terre*,  
Editions Alternatives, Paris, 1985).
- El-Wakil, Abdel Wahed  
1981 "Profile and El-Wakil's buildings in the Middle  
East", in *Mimar: Architecture in Development*  
no. 1.
- Fathy, Hassan  
1973 *Architecture for the Poor: An experiment in Rural  
Egypt*, University of Chicago, Chicago.  
1986 *Natural Energy and Vernacular Architecture*, The  
University of Chicago Press for the United Nations  
University, Chicago/London.
- Houben, Hugo and Hubert Guillaud  
1994 *Earth construction: A comprehensive guide*,  
CRATerre-EAG, IT Publications, London.
- Joffroy, T., with H. Guillaud  
1994 *The basics of building with arches, vaults and  
cupolas*, CRATerre-EAG, SKAT, St Gallen.
- Khalili, E. Nader  
1983 "Iran: Geltaftan", in *Mimar: Architecture in Devel-  
opment* no. 8.
- McHenry, Paul Graham, Jr.  
1984 *Adobe and Rammed Earth Buildings*, University of  
Arizona Press, Tucson/London.
- Norton, John  
1990 "Building in the Air and Ténéré region, Niger", in  
*Mimar: Architecture in Development* no. 34.  
1997 *Building with earth: a handbook*, IT Publications,  
London, 2nd (revised) ed.
- Steele, James  
1989 *The Hassan Fathy Collection: A catalogue of visual  
documents at the Aga Khan Award for Architecture*,  
The Aga Khan Trust for Culture, Geneva.
- Taylor, Brian Brace  
1990 "Ramses Wissa Wassef Museum", in *Mimar:  
Architecture in Development* no. 35.
- Theunynck, Serge  
1994 *Economie de l'habitat et de la construction au  
Sahel*, vols. 1 & 2, Editions L'Harmattan, Paris.