

CONSTRUCTION  
SANS BOIS



WOODLESS  
CONSTRUCTION

PROGRAMME CONSTRUCTION SANS BOIS

WOODLESS CONSTRUCTION PROGRAMME

Habitat et environnement  
*Shelter and the environment*

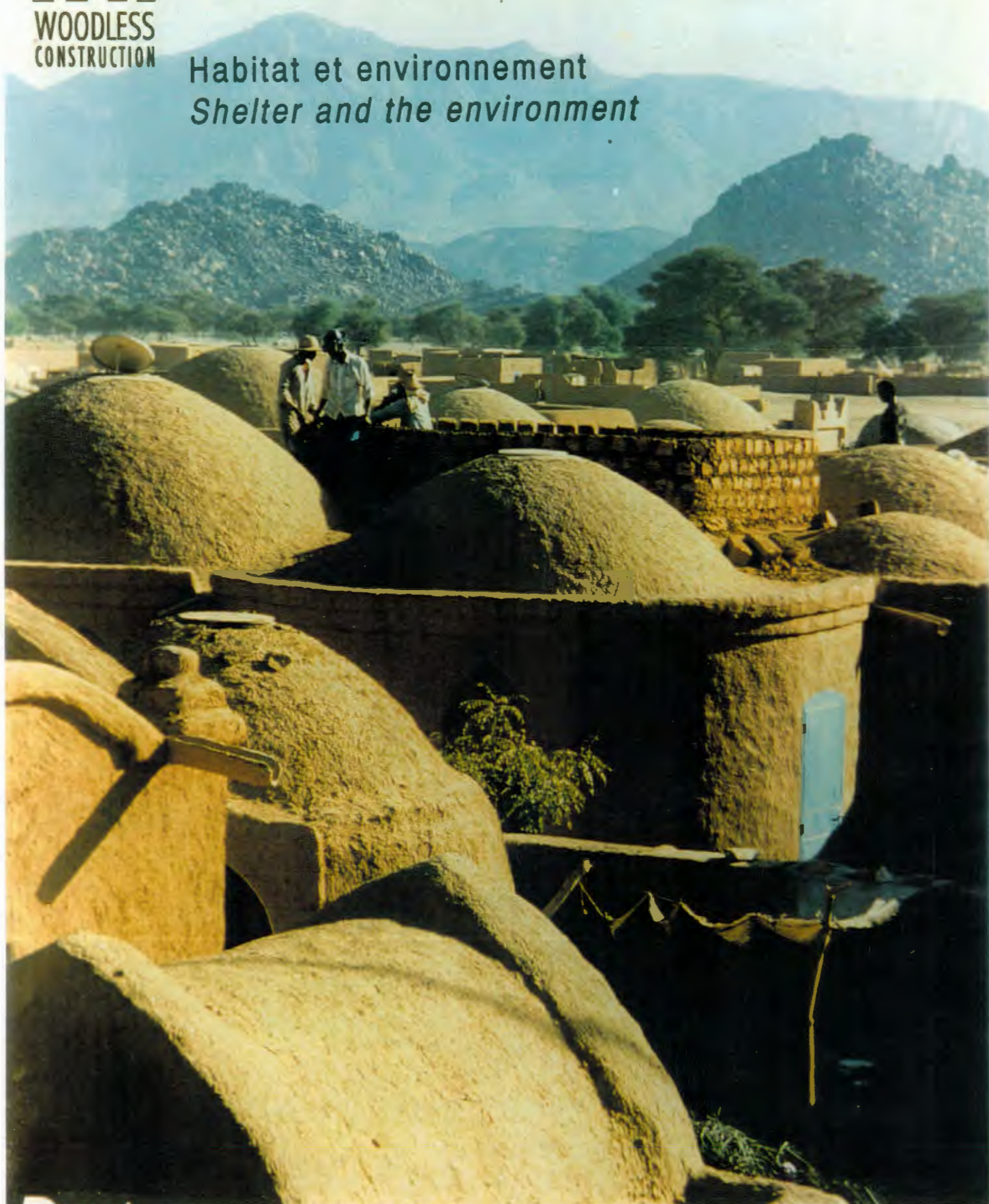

# WOODLESS CONSTRUCTION PROGRAMME IN NIGER, MALI AND BURKINA FASO

by

John Norton

November 1998

DEVELOPMENT WORKSHOP  
B.P. 13, 82110 Lauzerte, France  
tel: +33 563 95 82 34  
fax: +33 563 95 82 42  
e-mail: [devworks.france@wanadoo.fr](mailto:devworks.france@wanadoo.fr)

*Note: this submission in part draws on "Woodless Construction: unstabilised earth brick vault and dome roofing without formwork" by John Norton, Building Issues 1997, vol. 9, n° 2, published in 1998 by LCHS, the Lund Centre for Habitat Studies, whose kind permission to use extracts is gratefully acknowledged.*

*Design and layout: C. Norton*

*Cover photo: D. Miller. Other photo credits: D. McCormick, J. Norton, C. Tremblay, P. Tunley, M-L Uhde.*

# Contents

	page
<b>Preface</b>	
<b>Introduction</b>	
<b>1. Aims and objectives of the woodless construction programme</b>	
<b>2. The woodless construction programme</b>	
2.1 Overview	2
2.2 Background	3
2.3 "Traditional" earth building and earth roof building in the area	5
2.4 Choice of "woodless construction" options and criteria	6
2.5 Teaching "woodless construction" techniques	7
2.6 Modifications to the initial woodless construction technologies	10
2.7 Impact and brakes to assimilation	11
2.8 What does "woodless construction" cost the end-user?	12
<b>3. What are the benefits, and to whom, of "woodless construction?"</b>	
3.1 Home owners and institutional clients	13
3.2 Builders	15
3.3 Environmental benefits	15
<b>4. Financial statement</b>	
4.1 Context	16
4.2 Main funding partners	16
4.3 Woodless construction development costs since 1993	17
<b>5. Key innovative features of the scheme</b>	
5.1 Ownership	18
5.2 Listening	19
5.3 Gradual adaptation	20
<b>6. Why "woodless construction" techniques could be applicable elsewhere</b>	
6.1 Potential for replicability	20
6.2 Accessibility	21
<b>Not a conclusion: Towards the future</b>	
<b>Annexes</b>	
Annex 1: Examples of building plans for a range of woodless construction buildings	
Annex 2: Information sheets on village buildings	
Annex 3: Additional photographs – interiors	
Annex 4: Background and case study material	

## Preface

In September 1998, Development Workshop was able to visit Iférouane, in northern Niger, which had been virtually inaccessible as a result of Tuareg rebel activities for several years. In the 1980s this oasis village at the southern edge of the Sahara had been the focus of several years of training and demonstration building in "woodless construction" techniques – previously unknown in the area. No external support, technical or financial, had been provided in Iférouane since May '91<sup>1</sup>. Iférouane's situation, dramatic as it was for its inhabitants, provided a unique opportunity to discover what - if any – "woodless construction" activities were taking place after so many years of insularity.

This recent survey<sup>2</sup> and in-depth discussions with six out of Iférouane's seven most experienced builders revealed that:

- without exception, all sections of the populations in Iférouane have appropriated "woodless construction" buildings and these techniques are the only ones now used for new buildings:
  - the poorest live in small round houses built during training in the 80s; (photo 1)
  - middle-income groups typically request two or three room homes; (photo 2)
  - wealthier clients have commissioned large villas, with sophisticated finishings; (photo 3)
  - government services and public bodies, have turned to the techniques, (for the police station, the clinic etc.)
- the Iférouane masons trained in these techniques (fourteen in all) have organised themselves into two main teams; they are paid by the local inhabitants, at variable rates according to what the client can afford: 1750-2000 Fcfa (approx £2) per day for poorer villagers rising to 4000 Fcfa (approx £4) for wealthier clients;
- the masons' annual income from "woodless construction" building has risen very significantly since 1993, suggesting that related income-generating activities (brick-making, unskilled labour, local transport of bricks) have also increased although precise figures here are difficult to obtain;
- for their part clients appreciate the relevance of "woodless": (a) obtaining wood is increasingly difficult, expensive or illegal; (b) termites are a scourge which can entirely destroy an untended traditional wooden roof in less than a year; (c) imported "modern" materials are simply too expensive;
- since 1991 (i.e. without external support), 43 "woodless construction" buildings have been built:
  - in Iférouane itself: 15 for private clients (547m<sup>2</sup>) - a significant number at a time of inevitable economic stagnation; 3 for NGOs (82m<sup>2</sup>); and 3 for the State (177m<sup>2</sup>);
  - in the surrounding area, 22 buildings (733m<sup>2</sup>), mainly for NGOs, but also for the State.

This document seeks to show:

- how and why such clear assimilation of "woodless construction" techniques into a local building vernacular has occurred, or is currently occurring, not only in Niger, but also in Mali and Burkina Faso (section 2);
- what benefits these techniques bring and to whom (section 3);
- how the techniques and the dissemination approach could be applicable elsewhere (section 6).

---

<sup>1</sup> Two Iférouane builders had been able to leave Iférouane to attend a "training of trainers" course in the south of the country in 93 and in 94.

<sup>2</sup> Survey and report by Marie-Line Uhde, DW, September 1998.



*Photo 1: Round domed room, Iférouane, northern Niger.*



*Photo 2: Combined domed rooms, built by an Iférouane mason for his own family.*



*Photo 3: Recently completed (98) villa using a combination of vaulted and domed rooms, Iférouane.*

## Introduction

"Woodless construction" techniques not only use no wood, as the name indicates; they also require no presses and no cement.

With hindsight, a name which conveyed all three of these pieces of information would have been helpful, since the techniques are frequently confused with similar applications which rely on the use of cement (or lime) stabilised, mechanically compressed earth bricks.

The current "woodless construction" programme in West Africa has evolved from the vault and dome roofing using hand-moulded, sun-dried bricks which originated many centuries ago in the upper Nile basin, as one response to the quasi absence of wood in arid conditions. Similar materials and techniques were used for centuries with perhaps even greater skill and ingenuity in present-day Iran. Hassan Fathy famously (and controversially) tried to revive these techniques in Egypt in the 1940s - 60s. Development Workshop (DW) had the opportunity not only to work with Hassan Fathy as students in the early 70s, but also to learn at first hand from skilled craftsmen in Iran until the revolution cut short the integrated rural development project which DW was implementing and which used vault and dome roofing for a range of domestic and public buildings.

In 1980, DW was invited to Chikal, southern Niger, to run a short course to provide "on-the-job" training for half a dozen masons in vault and dome roofing, using hand-moulded bricks, whilst building a small literacy centre. A Canadian NGO<sup>3</sup> implementing a resource management project<sup>4</sup> there, had recognised that the massive consumption of wood in traditional roofs was a significant factor in the excessive cutting of trees in the region, (excessive meaning in excess of natural regenerative capacity). This over-consumption in turn contributed to desertification, aggravated by years of unusually severe drought. They considered that the use of earth vaults and domes for roofing represented a viable answer to this problem, arguing that these used locally available mud bricks, no machinery, and suited the climate.

To an extent they were right. But as all too many failed projects which rest on a valid argument can testify, this alone does not explain why "woodless construction" appears to have been adopted by masons, clients and increasingly state organs in several West African countries. This submission naturally presents events and developments in a historic and logical framework. But let us acknowledge here that an alchemy of skills, both technical and managerial, of individuals – both West African and foreign - prepared to make immense personal commitments, of organisations being "in the right place at the right time", of donors with appropriate designated funding priorities, and even of good harvests, have all played their part. It would be impossible to try to judge to which "woodless construction" owes the most.

---

<sup>3</sup> ISAID.

<sup>4</sup> *Projet Tapis Vert*, based in Filingué, southern Niger.

## 1. Aims and objectives of the woodless construction programme

The primary aims of introducing woodless construction techniques to West Africa are:

- to contribute to a reduction in the consumption of timber in building;
- to facilitate the building of decent and durable buildings by all sections of the population of the region in a sustainable manner;
- to reduce pressure on increasingly scarce wood resources, in a fragile natural environment under pressure from rapidly evolving social needs.

More specifically, the woodless construction programme as a whole has the following objectives:

- to introduce to the local population building techniques which reduce dependency on non-local resources (including "imported" from elsewhere in the country or the region) as the organic resources traditionally used get more scarce and more costly;
- to provide an alternative building technique using a familiar local resource (hand moulded bricks) to those for whom imported materials are simply financially inaccessible;
- to provide training to a sufficiently large number of masons to achieve "cruising speed", i.e. a resource which is both sufficiently visible to be in demand, and sufficiently competitive to avoid over-pricing;
- to train local trainers from amongst the best of the builders, which both increases local confidence and credibility and provides a sustainable future for the techniques;
- to increase the generation of local, monetary revenue through the training and employment of local builders (and trainers) and through more organised use of local materials and transport;
- to improve traditionally female revenue opportunities (pottery, soap-making, etc.) through provision of suitable buildings, and to involve village women in decision-making processes on local building needs (photo 4).



*Photo 4: Post-survey discussion of women's domestic building needs, Sévaré, Mali*

In broader terms, the woodless construction programme also strives:

- to raise awareness at all levels of the links between building and environmental resource management, between building and health, and between building and local income generation;
- to strengthen the emergence of civil society by using wherever possible local groups (e.g. youth groups, or mothers' groups) as vectors and by encouraging the creation of local non-profit organisations or builders' groups to "market" the techniques.

## 2. The woodless construction programme

### 2.1 Overview

In 1980 an integrated rural development project<sup>1</sup> in Niger became aware of local problems in obtaining organic materials, notably wood, for traditional housing. This problem was and is part of the larger problem of desertification - natural resources becoming increasingly scarce; the people who depend on them aggravating the problem by over-consumption forcing them to search for alternatives.

Development Workshop was invited by the PTV to introduce domes and vaults as an alternative to the use of wood and branches in flat roof building in an initial training and demonstration project at Chikal, southern Niger. Quickly it was clear that changes were needed to make the techniques easier to learn and to suit the climate. PTV staffer, Peter Tunley, (later a DW Associate), took up the crucial process of developing and adapting the techniques to suit the Sahel context. Tunley moved on to the WWF-sponsored Air Ténéré Project, northern Niger, where infrastructure was needed, and where "woodless construction" buildings complemented the project's environmental management message.

These and similar projects provided an opportunity to build a wide range of demonstration buildings, from small structures to large and prestigious offices. They helped consolidate the reputation of the building techniques but there were few opportunities for training, other than "on-the-job"<sup>2</sup>.

It was not until the 90s that it became possible with support from the Danish government and IUCN<sup>3</sup> for Development Workshop to launch a programme of dedicated training courses for local builders in Niger and to some extent in Mali, the main purpose of which was not the construction of buildings, but rather the development of builders' skills. Subsequently, the Danish and then the Burkina Red Cross have provided similar opportunities in both Mali and Burkina Faso, with additional support from Lutheran World Relief. Other organisations have contributed by sponsoring trainees or commissioning buildings.

Eighteen years after the introduction of these techniques to Niger, builders from Burkina Faso, Chad, Mali, Mauritania, Niger and Senegal have received training. Development Workshop currently co-ordinates major "woodless construction" training and promotion programmes in Niger, Mali and Burkina Faso. Other organisations in the region, having sponsored builders for initial training, have gone on to use "woodless construction" regularly, thus disseminating the techniques further. Overall, currently demand for vault and dome building currently tends to be greater than the supply of trained builders. The techniques have shown themselves to be adaptable to a variety of needs and are an accepted method of construction in the region, in both the informal and formal building sector.

Especially important, the techniques have over the past ten years been adopted into the local building "vocabulary", with local builders trained in the techniques using them spontaneously, both for their own homes, and in response to growing demand from individuals and organisations, including state bodies.

This chapter seeks to show how, and to what extent, this assimilation of a new method of building has been, and continues to be, brought about.

---

<sup>1</sup> *Projet Tapis Vert*, implemented by Canadian NGO, ISAID.

<sup>2</sup> The Air-Ténéré Project, World Vision and the US Peace Corps all sponsored intermittent training opportunities in the period from 1987 to 1992.

<sup>3</sup> The World Conservation Union based in Gland, Switzerland.

## **2.2 Background**

### **2.2.1 The geographical context of the Sahel**

The Sahel is the semi arid region immediately to the south of the Sahara stretching from Mauritania to Chad, (see map overleaf), characterised by low rainfall ranging from less than 100 mm p.a. in the north up to 800 mm or more in the south. Rain, when it comes, is usually in the form of short heavy storms - 80 to 100 mm in one storm is not unusual - and mainly during the months of June to October. This characteristic of infrequent, but very heavy storms is a more significant factor than the annual rainfall figure.

Periods of drought in the past 25 years have contributed directly and indirectly to a reduction in the availability of trees and organic material traditionally used in building, both for light supporting structures and - more crucially - as timber for flat roofed earth brick houses.

Temperatures can rise to over 40°C in the periods before and after the rainy season, and drop at night to near freezing in the north, although these extremes of temperature are less marked in the slightly more humid south. Overall, ventilation plays an important part in achieving comfort inside buildings, and so too does good insulation. The winter period in December and January can be uncomfortably cold in the desert regions, and for the population cold can be more of a problem than heat.

### **2.2.2 Socio-economic context**

The north of the region is principally inhabited by Tuareg nomads, whilst in the centre and south there is a diversity of ethnic groups and activities: herding in the north gives way to crop production in the south, where the population is much more sedentary. The drought years contributed to increasing the sedentarisation of the nomads, and at the same time there has been a general migration towards the larger towns. Overall population growth averages 2,5 to 3,5% per annum but urban growth in Niger, for example, is nearer 7%. All of these factors contribute to added pressure on substantial organic building resources, notably in the periphery of towns where demand is greatest.

The financial position of most people is very poor, and for many families disposable cash is virtually non-existent. In this socio-economic context, many activities are undertaken in a spirit of mutual help, especially in rural communities. It is therefore at times difficult to place a monetary value on a product achieved thanks to non-remunerated participation and the use of materials which are available at no financial cost, but often at the price of considerable effort and environmental damage.

### **2.2.3 Target groups concerned by the problem**

In this overall context, "woodless construction" techniques are therefore relevant to the following target groups:—

- people who habitually use wood or branches in meeting their shelter needs, and who are now finding it difficult to obtain these materials, having to travel greater and greater distances to find what used to be a free, local resource, typically collected by women;
- people who still use wood, and have not yet encountered major difficulties, but where the rate of consumption will deplete resources in the foreseeable future;
- people who can no longer afford to use non local materials, in part as a result of the devaluation of the regional currency (in '94, by 50% in relation to the French franc to which it is tied), and who are (re)turning to wood roof building as an alternative;
- the state and agencies providing public facilities, where both the example and the saving resulting from not using wood stand as an example to others.

In terms of training, "woodless construction" primarily targets local builders, who are the key agents in introducing the techniques.

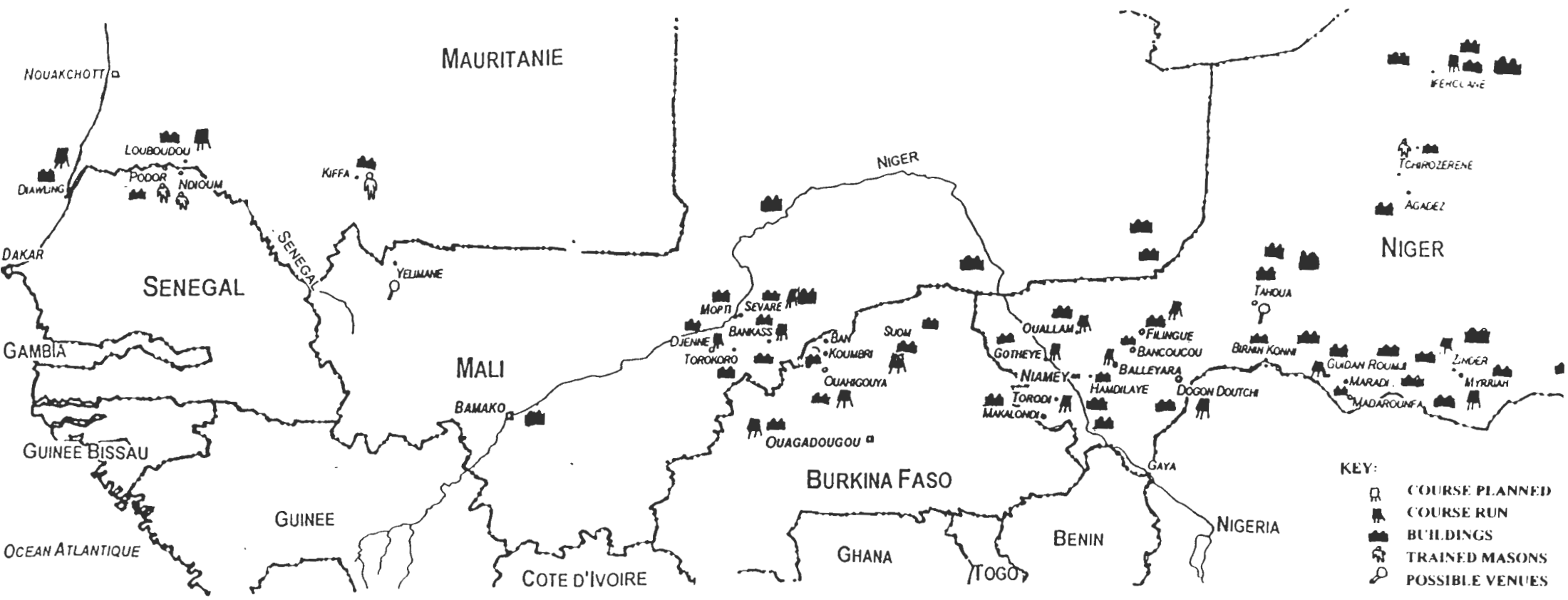

## 2.2.4 Building practices - traditional and modern

In the south of the region people have for centuries lived in buildings where the walls were made of mud and the roof either of mud and wood - beams and branches - or thatched in zones of higher rainfall. In Niger and Burkina Faso, granaries, and previously houses, were also built entirely in mud, using a form of coil construction similar to certain types of pottery. In areas where seasonal migration was common in the past, the process of sedentarisation had led to the use of more permanent shelters. In the northern areas, light structures (tents and round thatched grass-walled shelters) have been increasingly superseded by houses. In general these too have walls built from sun-dried earth bricks and roofs of timber beams, rafters and laths covered with mats and earth. Most traditional buildings consume significant quantities of organic materials, including grasses, straw, branches and tree trunks. Most also use earth as a building material. In many areas traditional practices and use of materials has not changed, although the species of tree used has changed significantly, shifting to less durable, less termite resistant species.

In the cities, and where the resources are available, more expensive materials may be used, including cement blocks for walls, some use of fired bricks and stone, and rarer examples of stabilised earth blocks. Roofs in the modern sector are either covered with corrugated sheets (iron or aluminium), or reinforced concrete, and both where available. Clay or more recently cement tiles with a wooden framework are also found. For the majority, non local modern products remain unaffordable.

## 2.3 "Traditional" earth building and earth roof building in the area

### 2.3.1 Earth walls

Earth building for walls remains the predominant method of building, and earth blocks are manufactured on the outskirts of almost all settlements. The size of blocks varies from settlement to settlement, and even within one location. Walls are normally plastered with an earth based plaster, to which additives including manure and straw are normally added. Some places have a reputation for skilled production of wall plasters, including using local tannic additives, and the durability of these can be excellent.

Local builders are responsible for much of the building work, but the quality of contemporary mud wall brick laying is often poor, with little attention paid to correct bonding or to filling joints.

### 2.3.2 Earth roof construction



*Photo 5: "Traditional" flat roof under construction showing massive use of timber beams.*

The main method is to lay timber beams across the width of the room. (Photo 5) Smaller sticks and branches are laid between these, and matting placed over the sticks. Earth is then compacted on top of the matting. The gentle slope of the roof provides for rain water run off, although with time decay of the timber and added layers of earth mean that the roof may sag in the middle. When this happens, water soaks into the roof, increasing its weight and it is not uncommon for flat roofs to collapse under the added weight, usually without any warning.

Traditional Hausa roofs in Niger replaced beams with a curved framework of sticks encased in mud, forming the "ribs" of domes. (Photo 6) Laths were placed between these ribs and a coating of mud covered over this supporting structure. A very few examples of vaults built with these techniques also existed.



*Photo 6: Traditional Hausa roof, Niger.*

As finding long pieces of wood has become more difficult, one option for building sizeable rooms has been to place a central pillar, on which shorter beams could rest. A more recently observed phenomenon is the use of IPN joists (by the few who can afford them) instead of timber beams; these are then covered with smaller branches, mats and earth in the traditional way. Termite-damaged beams are sometimes replaced by an interior masonry arched wall, splitting one room into two. All these "solutions" testify to the decline in the availability of timber beams and/or the increase in their cost, and usually result in narrower spaces. Builders using "woodless construction" appreciate the possibility of spanning larger spaces.

#### **2.4 Choice of "woodless construction" options, and criteria affecting this choice**

When invited to demonstrate earth vault and dome construction in Niger in 1980, Development Workshop initially chose to use vault and dome techniques originating in Egypt. Compared to other methods, and particularly those common in Iran, these had the advantage of being relatively easy to learn.

## The dome

The Egyptian dome building method makes use of a radial guide - usually a piece of string - to help builders find the correct position and angle of each brick; (see below).

## The vault

The shape and high span-to-height ratio (around 60%) of the Nubian vault (see below) makes it both strong and capable of being built on relatively thin walls (compared to the requirements of the lower profile Iranian vaults).

Furthermore, these techniques could use hand moulded earth bricks, earth mortar and traditional plasters - all familiar local resources as outlined above- and needed a minimum of special equipment. The good climatic performance of earth vaults and domes was also an important criteria.

### The Nubian dome

Horizontal, concentric courses of unstabilized mud bricks are laid first at a shallow angle and then more sharply inclined as one goes higher and towards the centre.



The position and the angle of each brick is shown by a wire or a radial arm (shown here) which rotates around a central post.



Single domes can cover square as well as round spaces. Several domes together, or a combination of domes and vaults, can be used to create varied and interesting forms and interior spaces.

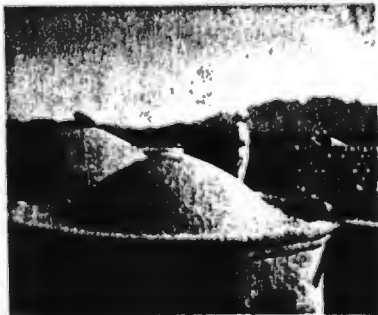

### The Nubian vault

The vault, in the form of an inverted parabolic curve, is built up in vertical courses which are inclined towards a supporting wall.

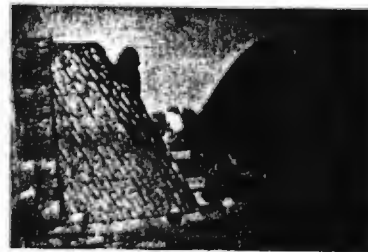

Thanks to the shape of the vault and the inclination of the courses, the bricks remain in place during construction without shuttering.



Vaults tend to be used to cover rectangular spaces. Several vaults of widely differing heights and spans can be combined with highly effective results.

## 2.5 Teaching "woodless construction" techniques

### 2.5.1 Deficiencies of "on-the-job" training

Until 1987, the introduction of these vault and dome building techniques was undertaken in Niger in the context of various programmes linked to rural development and to the management and conservation of local resources. The primary objective was to build rather than to train. Ad hoc "training" on-the-job, meant builders of widely varying experience and qualifications working on the construction of one or more buildings. Although this provided opportunities to learn, not everyone could be exposed to the same experience. For example, more skilled builders were naturally assigned to the more complex tasks.

Such on-the-job training, although by no means totally unsuccessful, did not however allow all the masons involved to be trained in all stages of the building process - from laying out to finishings. Normal site pressures meant that there was no opportunity for repeating the same operation several times (laying out, choosing a brick pattern, building the vault or dome etc.). The builders therefore typically emerged with an incomplete view of the whole process, and this was a serious deficiency, since knowing how to build a vault or a dome without also knowing how to build adequate foundations and strong walls is potentially dangerous.

### **2.5.2 Dedicated builders' training programmes**

Recognising the deficiency of on-the-job learning, from 1987 onwards opportunities were sought to run dedicated training, as opposed to primarily construction, programmes. These included practical exercises of various construction stages (knocking down and rebuilding), and opportunities to learn the principles behind the structure of the buildings. The improvement in the overall understanding of the techniques amongst builders and their subsequently better quality work on "real" construction sites, confirmed that a dedicated programme of training of builders and of local trainers was necessary if the vault and dome techniques were to achieve wider use. With this in mind, from 1992 onwards funds have been obtained to provide training courses on a regular basis in Niger, Mali and Burkina Faso for builders and technicians with different levels of experience.

#### *Builders new to Woodless Construction techniques*

Trainees participate in an eight week course, typically composed of —

- two weeks theory and practice on training structures ; (photo 7)
- five weeks learning on the construction of small buildings from laying out through to completing the structure ;
- one week theory and practice on aspects of finishing the roof, placing gutters, and selecting plasters.



*Photo 7: Trainee builders practise on training structures*

Between 32 and 40 builders are trained on each course. Trainees work in groups of four, under the responsibility of an assistant trainer. Each team is responsible for its own building, constructed for a genuine client in the community who contributes labour and materials. The course is run by a local head trainer, responsible for theoretical teaching inputs, organising demonstration work and supervising the quality of the buildings.

### Refresher courses

Three week refresher courses are organised for builders who have already participated in a previous course. More attention is also paid here to site management and the presentation of woodless construction to potential clients.

### Training of trainers

Two week courses are organised for training trainers drawn from amongst the most experienced builders. Depending on individual skills, they are trained either to the level of head trainers or to that of assistant trainers and site supervisors.

### Technician training

Opportunities are provided for technicians to participate in builder training programmes, since "hands on" practical experience is an essential part of understanding these techniques. Additional training, often in the form of individual teaching, is provided for design and understanding of the structure. These training sessions always have to be organised on a specific basis in the light of the time participants have available, which is often limited.

### 2.5.3 Teaching aids

Although it is always stressed that manuals alone should never be relied upon to learn how to build, Development Workshop has found that they are useful afterwards as a reference to remind trained builders what they have been taught. A sample page of the first *Guide*<sup>4</sup> was produced by Development Workshop in 1990 is given below.

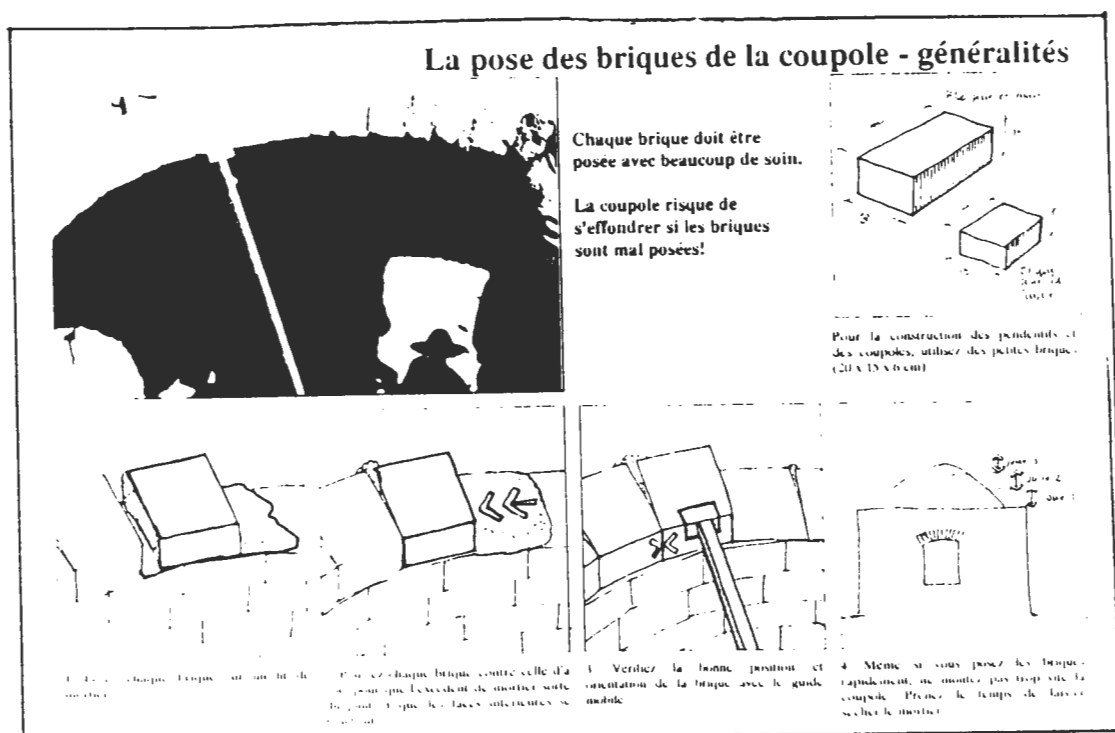

<sup>4</sup> Development Workshop, "Toitures sans bois: Guide pratique", with funding from the IUCN Air Ténére project based in Iférouane.

The *Guide* gives step-by-step guidance on how to build simple square and round domed buildings, and rectangular vaulted rooms. This used photographs and drawings (see sample page below), with minimum explanatory texts under each drawing, in an effort to overcome difficulties of literacy and language, and photographs to clarify the meaning and scale of the drawings.

To support the training process, a Trainers' guide<sup>5</sup> was produced in 1993, since when it has been revised at least annually, to incorporate trainers' comments and any technical amendments. The guide constitutes the basis of the training programmes and their curriculum. It includes how the teaching should be done, what demonstration or practice structures need to be prepared or built in advance of the training session, and which key points need to be particularly stressed. It also includes revision sheets to be used for the final stages of the course. Trainers typically meet, review and discuss the page(s) dealing with a particular aspect the day before the actual training session.

Trainee builders in turn receive a shorter "aide-mémoire" document, which summarises each item they have been taught, for their own use. They also receive a certificate, confirming the level of skill they have achieved and thus what type of building they can reasonably - and safely - be expected to achieve: this helps them in negotiating with their clients.

Finally, for use both in training and in awareness-raising activities to a broader audience, the training teams have a 20 minute video<sup>6</sup> explaining the objectives of woodless construction, a set of slides illustrating key technical points, and they are encouraged to use simple models for some of the explanations (e.g. miniature, scale bricks to illustrate bonding patterns).

## **2.6 Modifications made to the initial woodless construction technologies introduced**

### **2.6.1 Continuing change**

Adapting the "woodless construction" techniques to the local context has been an ongoing process, fed by observation of difficulties encountered and local building practices and needs, and has focused on two main aspects:

- making the techniques easier to learn and use, and thus safer;
- making the techniques respond to local needs and expectations.

The latter often reflect very local conditions and habits, and are not necessarily promoted throughout the Sahel.

The programme has also had to recognise that "good" building practice must be compatible with pragmatic building methods that builders are likely to continue to use after training.

The main technical changes are briefly summarised below.

- brick laying has in recent years been changed to "headers only"
- the laying of the building uses *the brick itself* as the unit of measurement
- a wire mud brick saw is used to trim openings to the desired size to avoid complex bonding
- builder quickly and accurately draw the curve of the vault using wires and based on the subdivision of any given vault span into thirds
- vaults are started simultaneously from both ends, and guiding strings are stretched from one end to the other
- the radial arm that is used for positioning each brick in the dome is displaced usually by one third of the dome's radius, giving a steeper curve to the profile of the dome,

---

<sup>5</sup> Development Workshop, "*Guide des formateurs*".

<sup>6</sup> Development Workshop, "*La Construction Sans Bois*", produced by Annick Turner.

reducing outward thrust, and enabling the dome to have a spring point lower down than a hemispherical dome

- smooth gentle curves in the valleys between the roofs are angled to avoid water flowing too fast - causing erosion - or too slowly, causing infiltration
- wide open gutters that cannot easily be blocked are used
- where people required flat roofs, secondary vaults and domes, infilled in the "valleys" achieved this.

## 2.7 Impact and brakes to assimilation

### 2.7.2 Impact

Although the Woodless Construction Programme had visited over 600 sites by early 1997, after 18 years a comprehensive list of woodless construction buildings no longer exists, since there are many more buildings being constructed spontaneously from eastern Chad to the Atlantic coast of Mauritania. We do, however, have some indicators of the geographical and building impact of the programme as a whole.

- In 1996 a mission to Gao in the north east of Mali found seventy buildings that had not been seen before, following training that had taken place 8 years earlier.
- The Preface cites a similar situation in Iférouane, northern Niger, i.e. 43 buildings without technical or financial support in the area.
- A recent report<sup>7</sup> on IUCN's 5 year programme in Niger stated that the techniques were accessible in 70% of the country, and that 608 buildings had been built by families, national institutions and village non-profit associations.
- A local NGO<sup>8</sup> operating in the Tahoua region of central Niger has recently informed DW that since sending 4 masons for training in 1994, they have formed a masons' association<sup>9</sup> which has completed some 3,150m<sup>2</sup> of woodless construction, i.e. approximately 70 buildings, mainly for institutions but increasingly for individuals.<sup>10</sup>
- In Burkina Faso, "woodless construction" has become a major component of a Red Cross programme to improve conditions and the environment in the whole of the north of the country.
- In Mali, numerous agencies including the Red Cross and the European Community have made "woodless construction a key part of their environmental management programmes.
- The Malian army and airforce increasingly use the technique for meeting their accomodation needs.
- The "waiting list" for "woodless construction" buildings in 1997 in Niger alone was estimated at 400.

### 2.7.2 Brakes to assimilation

The main public and institutional concern is resistance to rain - unjustifiably. Rain is not a problem, provide that it does not continue for a very prolonged period.

Examples speak louder than words. In 1994 rainfall in the Sahel exceeded the past 20 year average by 30%. A regional survey showed that less than 1% of woodless construction buildings had problems of rain damage on the roof, invariably caused by poor infilling in the roof valleys. A slightly greater number of buildings had problems that came from poor choice of site, where there was insufficient drainage at ground level. Not a single "woodless construction" building collapsed. Meanwhile, in Niger that same year at least 18,000 wood roofed houses collapsed, leaving 120,000 homeless.

<sup>7</sup> "Bilan et perspectives -activités 1993-1997. Programme Construction Sans Bois, Niger", June 1998, by IUCN/DW.

<sup>8</sup> PROFORMAR : Programme for modular training to promote rural craft skills.

<sup>9</sup> UNIC: Niger builders' union.

<sup>10</sup> Source: letter from J-L Arrachart, Proformar project manager, to DW, dated 3 November 1998.

Heavy rains in 1998 have similarly increased demand for "woodless construction" buildings, as people observed that these performed better than traditional roofing.

Maintenance needs are determined by weathering from erosion caused by rain. In the Sahel, rain storms come with great violence for short periods, and invariably from the east: these are therefore the walls that need protection, and this is achieved by good orientation to minimise the exposed facades and good roof design, to minimise unnecessarily exposed roof profiles. Good wall renders, planting protective trees and careful site planning can all help reduce the effect of driving rain.

## 2.8 What does "woodless construction" cost the end-user?

Putting a comparative price on the cost of buildings in the Sahel is difficult, because real costs range from construction with collected materials and contributed labour through to construction with all materials and labour paid for. The table below<sup>11</sup> based on figures in 1995 show the difference between the main types of construction in the private sector. In sum, this shows that woodless construction compares favourably with mud walled buildings with wood and earth roofs, but this depends on two bases for comparison:

- if good wood - which is expensive and hard to obtain but which should be durable - is used, woodless construction is cheaper and at least equally durable;
- if poor quality wood which has very poor durability (as little as two years), is used - and this is increasingly the case - woodless construction is more expensive to build initially, but will last many years longer, so that the additional cost is quickly "amortized".

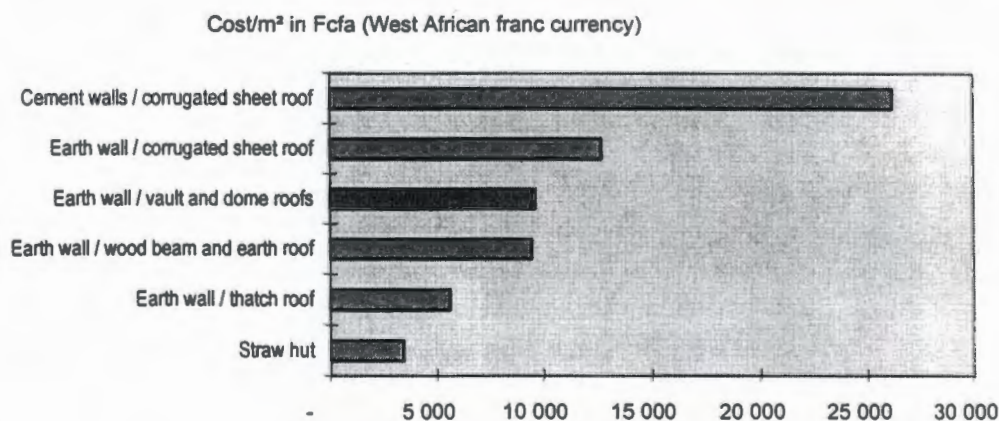

Clearly durability is a key factor, particularly where termites are a major problem.

Apart from durability, another key factor, which the table also does not show, is the increasing "monetarisation" of the building process. Thus the cement building represents almost 100% paid material, and in most instances, paid labour, whereas the thatched hut can be achieved entirely using collective labour, whose only recompense is meals and a final celebration. The use of non-local materials is constantly increasing in cost, making woodless construction more attractive, whilst the increasing scarcity of wood makes it harder for people to build with what used to be collected materials.

<sup>11</sup> Figures and the table developed by Marie Line Uhde, Development Workshop, in CIDA sponsored research reports on *Relations entre Habitat Humain et Ressources Naturelles (Mali & Niger)*, DW, 1995.

### 3. What are the benefits, and to whom, of woodless construction?

#### 3.1 Home owners and institutional clients

The main beneficiaries are the people who live and work in woodless construction buildings. Women and children can be considered to benefit most, as they spend more time in the home compound. Women also benefit by not having to walk increasingly long distances to collect wood, traditionally their role.

Owners range from owner/builders in the villages through to government clients, and their buildings are equally varied, from small one roomed houses (photo 1) to large hospital complexes. (photos 8 and 9) For almost all users, it takes one or more years for individuals to be satisfied that these roofing techniques work. Demonstration buildings for more adventurous clients therefore play an important role in developing confidence.



*Photos 8 and 9: Vaulted corridor and domed room, maternity clinic, Bonkougou, Niger.*

Most occupants mention climatic comfort and the size of rooms as being the main advantages. For wealthier owners, the low cost (compared to imported materials) is often a reason for choosing woodless construction, but increasingly woodless construction buildings are acquiring a prestige image. For poorer users, faced with increasing difficulties in finding good wood for roof building, the advantage of woodless construction is that one can make the bricks oneself, and achieve a durable and comfortable building. And although a woodless construction house is initially more expensive than similar building covered with poor quality wood (see graph), people know that it lasts much longer.

Villagers in Niger taking part in a current region wide programme for building cereal banks (photo 10) in Niger, when choosing whether to build a flat timber roofed grain store or one using woodless construction, invariably choose woodless construction because they can provide the materials more easily and they have confidence in the product.



*Photo 10: Cereal bank, Niger; low openings for ventilation and maximum useable space*

The buildings provide good thermal properties, because their thermal mass reduces the interior differences between hot and cold periods in the day. But in reality where overall temperatures are very high, the buildings stabilise but do not reduce average temperatures. Thus creating cross ventilation will contribute much more to interior comfort, and careful design ensures that Woodless Construction buildings provide a good example, not least because ventilation reduces health risks such as meningitis. For the local population, paradoxically thermal protection in the cold season is more important, and the buildings work well in this respect.

In Burkina Faso, a range of simple buildings has been developed to introduce woodless construction techniques to "new" villages as part of the Burkina Red Cross environmental education programme (see Annex 2). Most of these are linked to local, often traditionally female income generating activities (pottery, soap-making), thus providing a more comfortable working environment.

## 3.2 Builders

The second group of direct beneficiaries are the builders whose skills and income generating potential are improved.

Across the region, "woodless construction" has been taught to the following number of builders since 1993:-

- in Niger: 428
- in Mali: 199
- in Burkina Faso: 93

A small number of these builders travelled for training from other countries (notably Mauritania, but also Chad and Senegal).

In addition, 28 architects or technicians in Niger have also received training.

In an average year, about 60% of the masons are actively involved in woodless construction, through work on building sites, and in training activities. Woodless construction therefore represents a significant activity for many builders, even though a very high proportion will spend five months of the year also looking after their crops in the rainy season.

However, building work that comes to them in the villages is often unpredictable, and depends on factors such as the harvest. In a poor year, few people will build. But the development of woodless construction in the formal building sector is both giving work and income to trained builders on a steadier basis: a good woodless construction builder can count on getting work and using his skills.

The drawback for the villagers is that the formal sector - and the training programmes themselves - take the best builders away from their home village, depriving the community of continuous access to their skills. Many builders, however, do return to their homes and build for themselves, and this in turn prompts their neighbours to build in the same way.

A final aspect under this heading: woodless construction is certainly important in bringing skills and work to rural builders, but it has been equally important in restoring their pride in their work. Building without good quality wood is not a rewarding task, and building with imported materials unreachable to all but a handful. Woodless construction has helped redress this balance: woodless construction techniques and those who know how to use them are regarded with respect.

## 3.3 Environmental benefits

In the long term, the environment benefits, through better resource management and reduced pressure on organic material in the region. This is now regionally recognised as a long term goal to improve living conditions and preserve the natural environment.

When comparing a wood/earth roofed house with a woodless construction roof, a 20m<sup>2</sup> dwelling represents a saving in wood of at least 60 linear metres of timber beam and 12 cubic metres of battens placed between the beams. Considered in terms of the annual increase in population and building demand, this represents a huge potential reduction in the number of trees needing to be cut to provide building timber.

In Niger, where woodless construction was first introduced, it is estimated that the following equivalent quantities of wood have been saved thanks to the construction of 608 woodless construction buildings over a 5-year period (93-97):

- 2,325 borassus palm trees<sup>12</sup> (trunks are need for the main beams of traditional roofs)
- 4,000 m<sup>3</sup> of shorter branches (used for the transverse battens)

Together this is the equivalent of 1,350 hectares of plantation.

## **4. Financial statement**

### **4.1 Context**

The "woodless construction" programme is being implemented in several countries by Development Workshop in collaboration with a number of donor partners and local organisations. Niger was the first country in which the techniques were introduced and developed, and has absorbed a considerable proportion of programme development costs.

The figures below represent programme costs since 93, when the first dedicated programme of training and awareness-raising was launched in Niger. Prior to that, training opportunities had been provided by various organisations, notably the WWF in northern Niger, principally as part of infrastructure building activities.

It is important to recognise in considering these figures that costs under "training" and "demonstration" have most commonly included building homes, and sometimes large and prestigious buildings (such as the maternity centre in Bonkoukou, Niger, currently being run with support from the Belgian government). The residual financial value of these buildings should ideally be extracted from the "training" and "demonstration" costs reported below, but estimates of what this value might be are not possible in the socio-economic context in which many of the more simple houses were built, i.e. with family or community provided labour and materials.

### **4.2 Main funding partners**

In Niger, major funding from Danida in collaboration with IUCN, was obtained for a five year period beginning in 1993. From 93 to 95, the same programme was also active in certain parts of Mali. Support was also provided by Lutheran World Relief, and there were opportunities for collaboration with other NGOs.

In Burkina Faso, the Danish and subsequently the Burkina Red Cross have been major partners since 1995, when "woodless construction" was integrated into their "Hope in the Desert" environmental education programme.

In Mali, the same Red Cross programme has provided support to the local woodless construction team (which formed a Malian NGO in 1998) since 1995, together with a basket of funders, including Lutheran World Relief and the European Development Fund.

---

<sup>12</sup> This is the preferred species, for its durability and termite resistance. Naturally, other, less durable species are increasingly being used.

### 4.3 Woodless construction development costs since 1993

	Niger FF	Burkina Faso FF	Mali FF	Total FF	Total £**
Programme design/assistance	2.5 M	1.7 M	0.8 M	5.0 M	0.53 M
Logistics and local staffing	4.1 M	0.5 M	0.7 M	5.3 M	0.57 M
Training, including building	3.0 M	0.5 M	0.5 M	4.0 M	0.43 M
Demonstration building	0.4 M	1.2 M	0.2 M	1.8 M	0.19 M
Misc.*	1.6 M	0.1 M	0.1 M	1.8 M	0.19 M
Total FF	11.6 M	4.0 M	2.3 M	17.9 M	
Total £**	1.24 M	0.43 M	0.24 M		1.91 M

\* Overheads, individual project evaluations, contingencies.

\*\* Exchange rate at Nov 98 (9.365 FF / £)

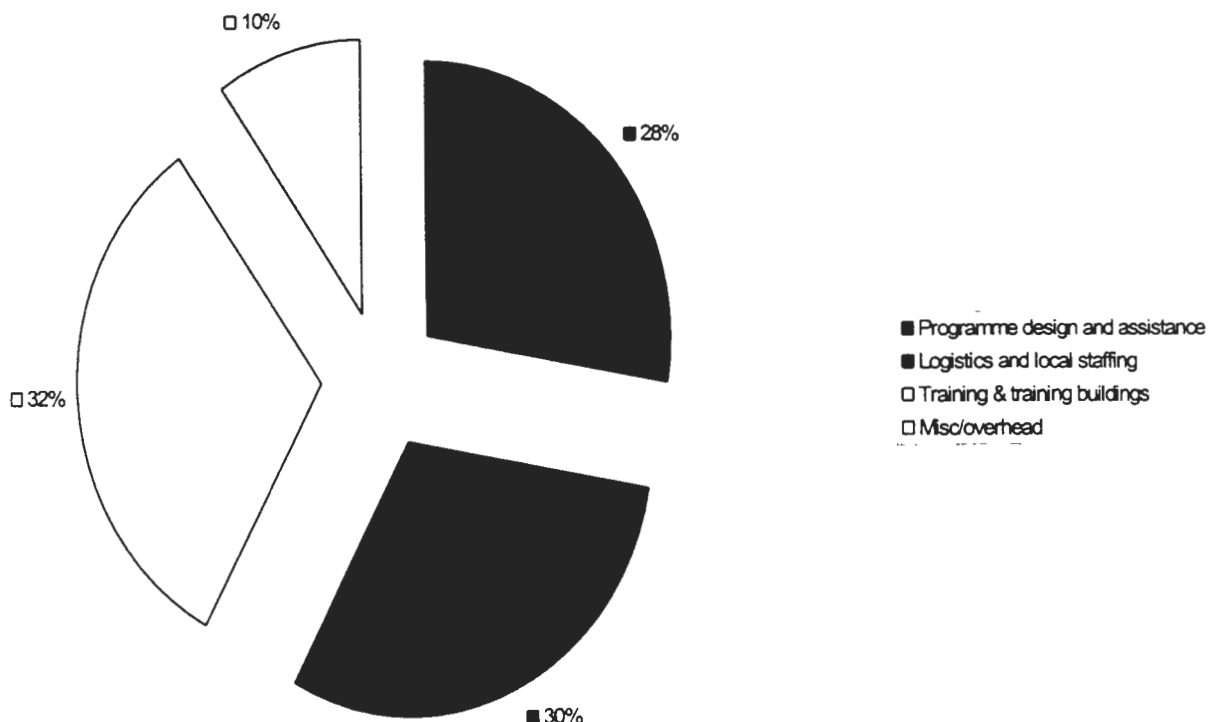

## 5. Key innovative features of the scheme

### 5.1 Ownership

Within the limitations of providing training in new techniques, "ownership" of woodless construction has transferred to the local population:

- masons are trained by their fellow mason-trainers, wherever possible in their local language or through local interpreters;
- the buildings they erect as part of their initial training courses have been commissioned by "real" clients, i.e. individual villagers, local or state organisations, who according to their means provide (photos 11 and 12) or pay for the materials and unskilled labour (and who "own" and care for the building accordingly);



*Photos 11 and 12: Village youth organisations in Burkina Faso undertake to provide the correct quantity of bricks, and on site earth, water and labour; only the skilled "woodless construction" building input is project-provided at this early "demonstration" stage.*

- subsequently commissioned buildings are a matter of normal negotiation between client and builder; builders are taught in refresher courses how to explain to potential clients the advantages of woodless construction, the main designs they are familiar with, and how these can be modified to suit each client's needs;
- although initially trained to build certain simple buildings safely – and they receive a certificate to show this - builders are also taught the principles on which these simple designs rest: the best among them can – and do! - innovate, combining shapes to create new spaces;
- similarly, decorative features are freely grafted onto woodless construction buildings (photo 13), at the request of clients or according to the taste of the builder.



*Photo 13: Decorative features, training centre, near Maradi, Niger.*

The role of the "woodless construction" programme is now to coordinate (but not to run) training courses; to provide ad hoc technical inputs; to regularly update the trainers' guide on which training is based; to monitor quality and offer technical support to trained masons; and to raise awareness further afield of the benefits and potential of "woodless construction". Future tasks include developing norms (see below).

The programme has also been up till now been best placed to obtain support from donor organisations and continues to do so. This role is, however, increasingly being taken over by local organisations, such as the Mali "building and the environment" NGO recently created by the local woodless construction team, which now negotiates directly with donors for medium-term support, as well as with clients to ensure future sustainability. Institutional support (helping to set up managerial and accounting systems, teaching computer skills, etc.) is thus an increasing part of the programme's enabling role.

## **5.2 Listening**

Linked to ownership, a guiding aim of the programme has been "listening" – to the builders, to the local population, to state services, to clients with relatively large or very small amounts of money to spend, to local groups representing various interests, including those of the very poor, and to NGOs – local and international – working in the area.

Hence the constant technical evolution, some of it described above, but also a shift in position, from *provider* to *enabler* as local skills and confidence have grown, and as more local organisations have become exposed to the techniques and use them independently.

### 5.3 Gradual adaptation

The programme therefore does not claim to be a successful example of a "south-south" *transfer*, (from ancient Egypt to modern-day Sahel), but rather a *medium to long-term, process of adaptation*. The emphasis has been on getting it right - or as right as possible in a given context - perhaps differently each time, rather than on statistics and on deadlines. Progress at times (in years of poor harvests for example) has seemed slow in a results-keen environment. But DW firmly believes that this step-by-step approach is a key feature of the programme. In a context of extraordinarily rapid change after centuries of essentially the same building practices, "gradual" is - after all - a relative term.

## 6. Why "woodless construction" techniques could be applicable elsewhere

### 6.1 Potential for replicability

Based on using local resources and labour, "woodless construction" or unstabilised earth vault and dome roof construction has potential in areas:

- where other resources are scarce,
- where labour is plentiful, and
- where the context is suited to these techniques.

By context, we refer not only to climate – it is a common misconception that "woodless construction" techniques can be used only in very arid areas (see para 2.7.2 above) – but also to the types of soil available (not all are suitable); the building culture (e.g. using skilled masons; regular maintenance of the home by the owner;); and socio-economic aspects (the way in which the home is used, by which members of the family, etc.).

Technically, this potential results from the following:

- "woodless construction" techniques have been shown to be capable of being assimilated by local builders and the local population;
- they suit both the formal and informal building sector: from building simple shelters and houses when the other local resources (wood, straw, etc.) have become scarce to building larger public facilities meeting high standards of comfort and cleanliness and responding well to modern needs;
- they stimulate local economies at national and village level and develop local skills by using materials and builders already in the existing building process; this is particularly significant for public buildings, often heavily dependent on non local materials and external skills;
- being highly labour-intensive, they require - in their simplest form - very little special equipment; this makes them well-suited to countries with large under-employed labour forces and little capital available for investment;
- helping to reduce imports (of building materials or the energy resources needed to produce them) which add to the debt burdens of many of the poorest countries.

Environmentally, the saving in wood used in the roofing of flat timber roofs can be considerable, (see 3.3 above), which makes "woodless construction" of particular interest to areas facing natural resource management challenges.

Architecturally, vault and dome roofing techniques provide the potential to cover a variety of different spaces, both in size and shape. The combination of several vaults and/or domes can be used in simple or more complex combinations to satisfy a variety of building requirements.

## 6.2 Accessibility

One of the aims of "woodless construction" is to be popularly accessible. This implies the following criteria, which in turn narrow the material and technical choices and how these can be taught:

- The roofing technique should make substantial use of genuinely local materials, that can be transported by local means, such as donkey carts.
- The production and use of the building materials should differ as little as possible from existing local practices where these are seen to perform perfectly adequately in the local context.
- The materials should exist in sufficient local quantity to satisfy a general demand for building materials.
- The roofing (and wall building) process should require as little specialised equipment as possible, so that lack of these items does not become a reason for not using the technique.
- The roofs should be built without needing a supporting formwork during construction, since formwork represents a significant piece of site equipment for builders to obtain and move around, as well as reducing flexibility in the size of roof one can build.
- The techniques should be relatively easy to learn.
- The techniques should be able to resist or attenuate the effects of the local climate.
- The techniques should be durable.
- The techniques should be affordable to low income groups.
- Once given the skills, the technique should lend themselves technically and economically to spontaneous building by local builders and the local population.
- The techniques should be sufficiently flexible to adapt to different local habits, styles, spatial requirements and building needs.

"Woodless construction" has demonstrated that it fulfils these criteria in the Sahel region. Where similar criteria apply, it may have a role to play.

## Not a conclusion : Towards the future

The success of "woodless construction" may in large part be due to never having reached a "conclusion", i.e. never having concluded that a given building design, a particular way of teaching, a dissemination method, etc. was "the right one". Constantly striving to modify the techniques to suit both masons' and users' needs and skills has been a key factor. This essential approach must continue, and not only in "new" areas.

This said, there are certain key aspects which we already know need to be addressed:

- "marketing" woodless construction, in particular enabling trained masons, who are the key players, to make the step from responding to specific requests to being proactive in explaining the techniques and seeking new clients; this in part depends on increasing the number of trained builders, since currently demand outstrips capacity in the Sahel region;
- developing technical guidelines or norms which builders can use particularly vis à vis institutional and state clients, some of whom demand insurance guarantees along European models, which are dependent on the existence of such norms;
- increasing awareness amongst clients of the need for regular maintenance; although unmaintained buildings have been shown to stand up well to the test of time (one example is still safely in use after 10 years without re-rendering), nevertheless ideally maintenance should be considered to be as routine as seasonal agricultural tasks; this is particularly true of state-owned or controlled buildings, such as schools, where local people do not spontaneously feel responsible for their upkeep;
- exploring avenues enabling the very poor, i.e. those with no monetary resources, to have access to skilled masons, perhaps through mutual guarantee loan schemes which have proved successful in certain contexts;
- providing a core of trained technicians and architects capable of innovative designing and ensuring professional quality control; this aspect is linked to that of norms.

Development Workshop's existing and anticipated programmes in Niger, Mali and Burkina Faso, and further afield (Mauritania, Western Sahel...), focus both on these future goals and on continuing to train and empower local masons and communities.

## **Annexe 1**

### **Examples of building plans for a range of woodless construction buildings.**

Drawings by Peter Tunley, DW Associate.

An example of the simplest units commonly proposed and one of the most popular: a small round building (reminiscent of the *case*, made from branches and grasses and typically built and owned by women). Vertical walls provide better rainwater runoff control.

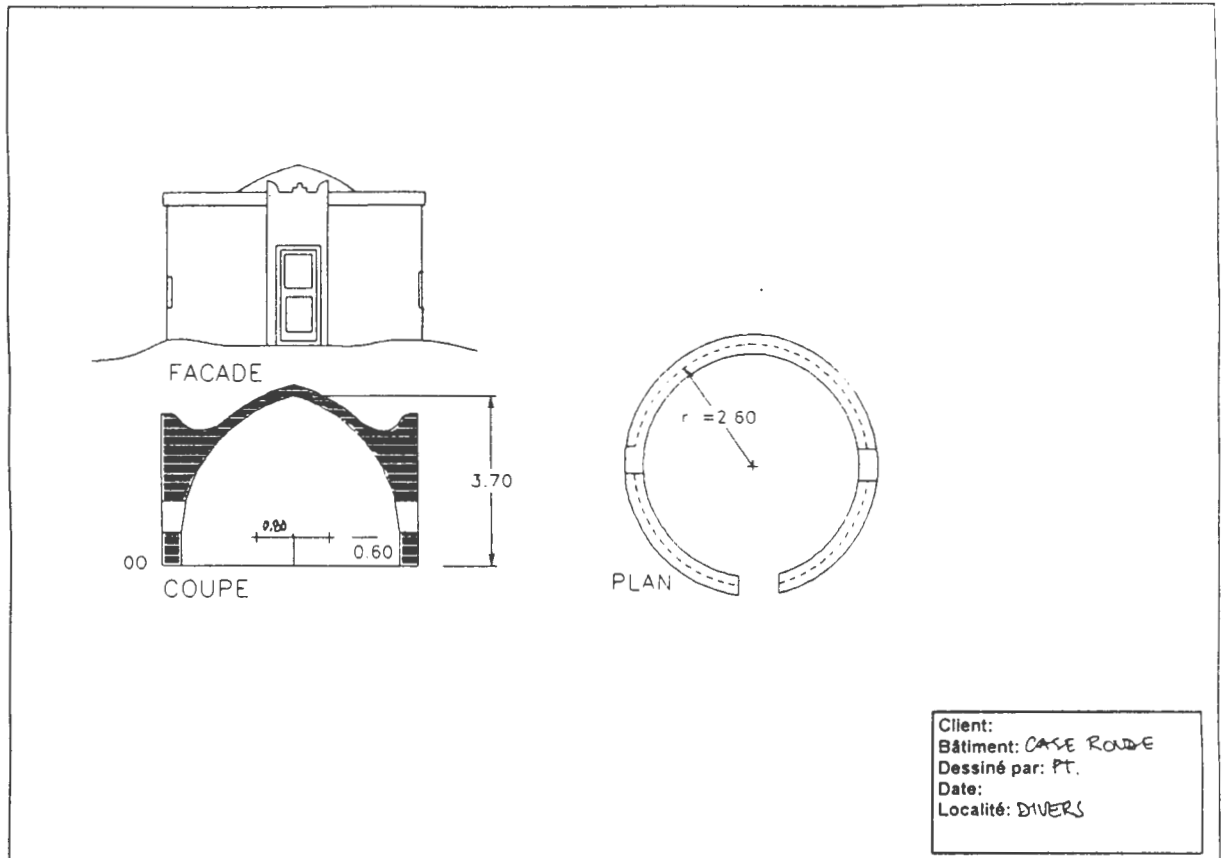

An extended version of the above - easy and economical to build.

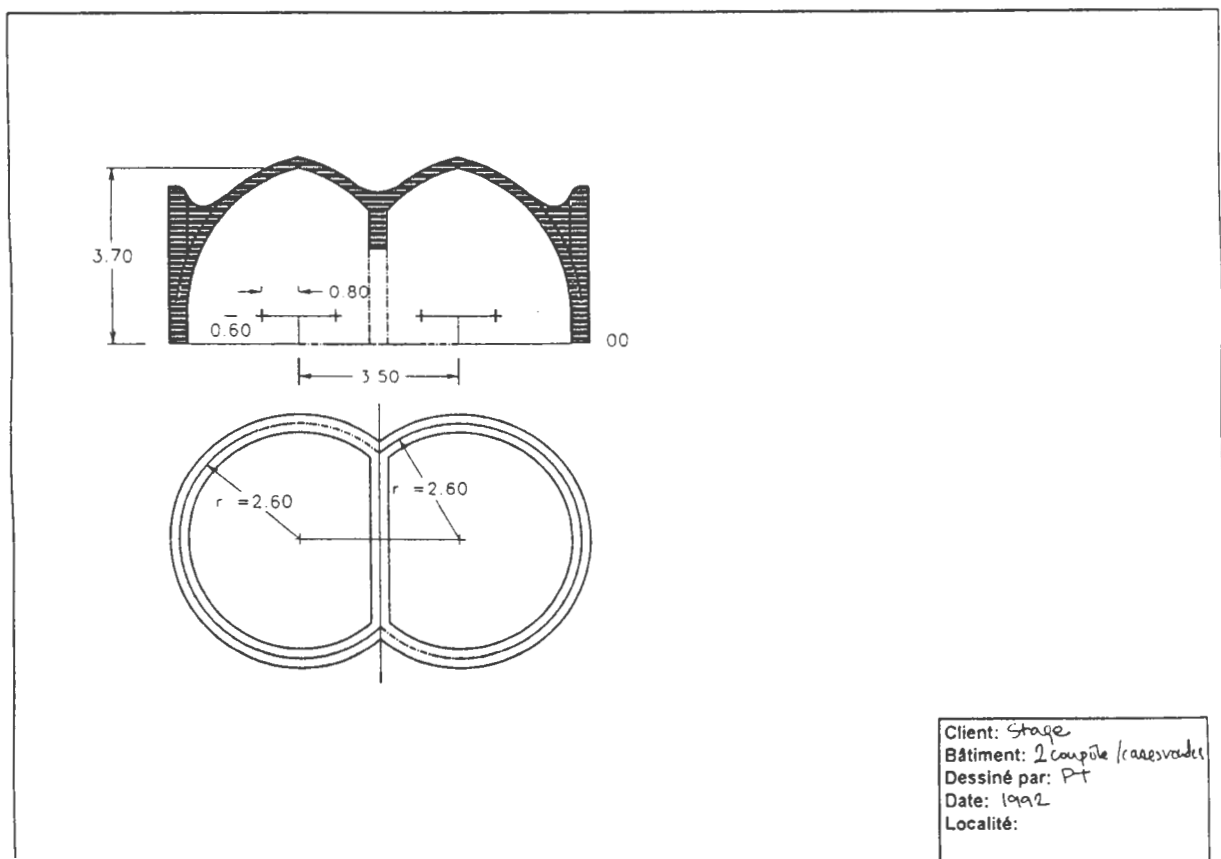

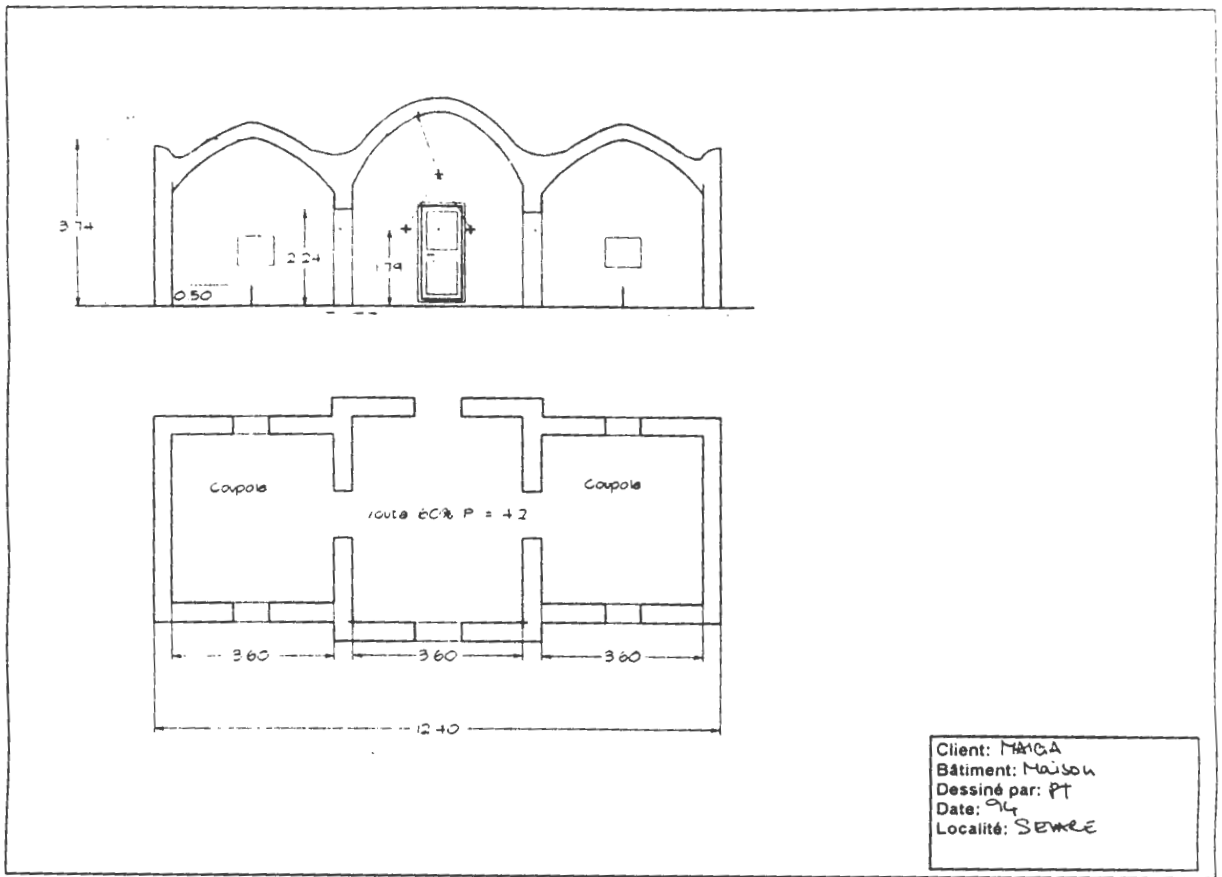

2 types of larger 3-room construction combining vaults and domes in different configurations. Popular amongst better-off clients and for small public facilities, these enhance woodless construction's image for meeting more sophisticated needs.

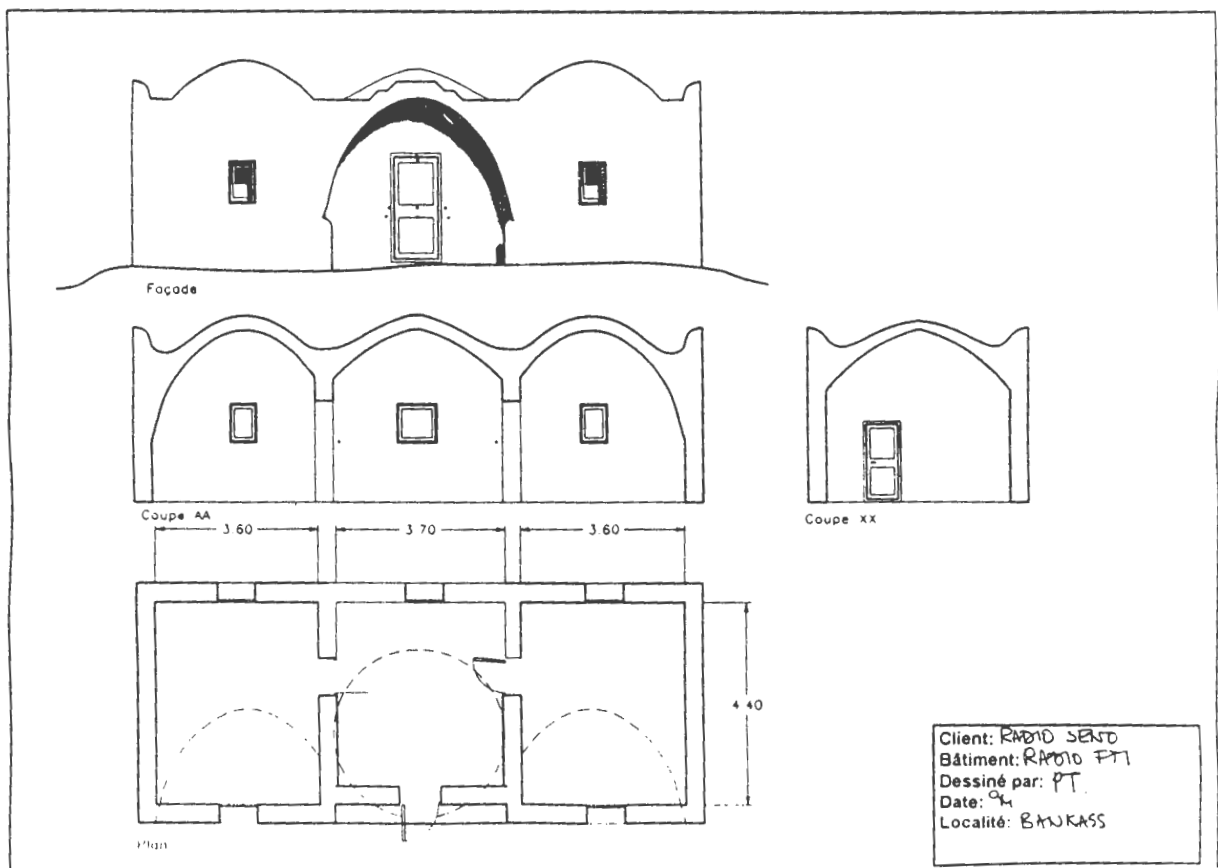

## Annexe 2

### Information sheets on village buildings

In Burkina Faso, "woodless construction" activities are still at a fairly early stage.

With support from the Burkina Red Cross, DW has run builders' training programmes and involves villagers in deciding which if any buildings they require. The project provides the skilled labour input (i.e. builders trained in "woodless construction" techniques), but a major contribution is expected from the village. This ensures that buildings are genuinely demand-, and not project-, driven; that they are perceived to be "owned" by the villagers; and that they are subsequently better maintained.

The following sheets can be used to assist this decision making process:

- they suggest a range of buildings which have proved popular (literacy centre, office/storehouse, meeting room etc.);
- they provide a visual image (photo) of the building;
- they give an estimate of the contribution expected from the villagers: for a given surface area, how many days (unskilled) work they would need to provide, how many bricks – large and small – that need to be made in advance, the amounts of water, earth, sand, gravel and manure to be provided (for mortars and renders)
- for the builders, the vault and/or dome coordinates are listed.

*Please unfold the French-English glossary at the end of the information sheets.*

# Le Hangar d'attente - réunions



## Devis pour la contribution du groupement villageois

Superficie en m <sup>2</sup>	Durée en nombre de jours	Nombre manoeuvres par jour	Grandes briques 38x24x12	Petites briques 20x15x6	Fûts d'eau 200 litres	Charrettes de terre	Charrettes de sable	Charrettes de gravier	Charrettes de fumier
14	14	15	2200	3300	50	80	10	5	3

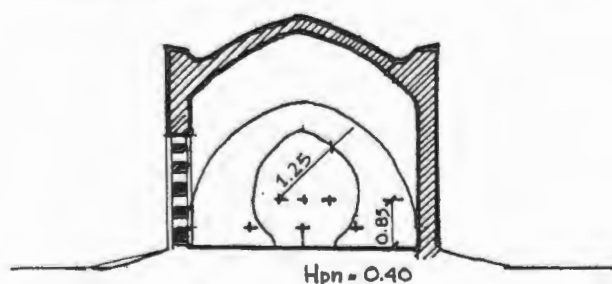

COUPE A-A

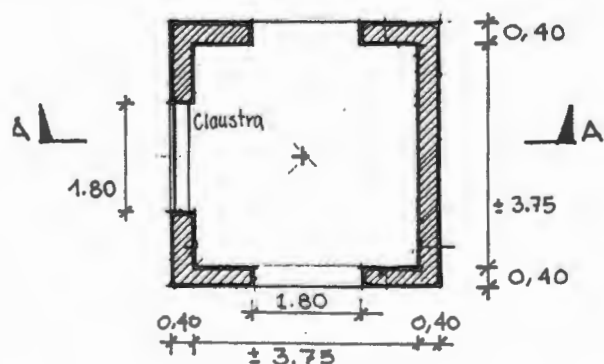

PLAN

### Coordonnées du toit

Coupole	Hauteur point de naissance	0.40 mètres
	Déplacement	1/3, soit +/- 0.90
	Dimensions pièces	+/- 3.75 x 3.75

Toutes les dimensions sont à confirmer sur site en fonction des dimensions des briques disponibles: implanter avec les briques

# Salle d'alphabétisation



## Devis pour la contribution du groupement

Superficie m <sup>2</sup>	Nombre de jours	Nombre Manœuvre par jour	Grandes briques, 39x24x12	Petites briques, 20x15x6	Fûts d'eau, 200 litres	Charrettes de terre	Charrettes de sable	Charrettes de gravier	Charrettes de fumier
28	30	15	4500	6000	130	180	15	15	5

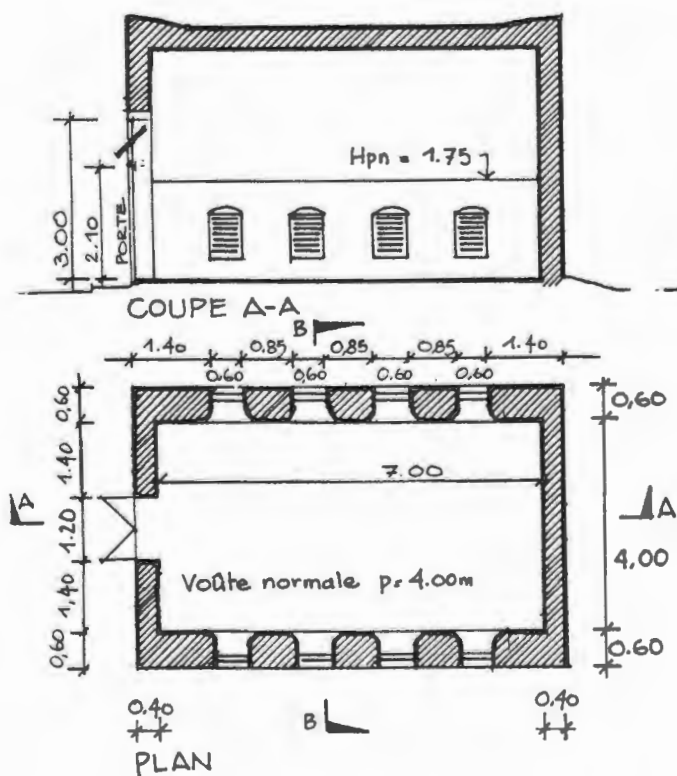

### Coordonnées pour la voûte

Hauteur point de naissance	1,75	mètres
Portée de la voûte	4,00	mètres
Portée de la pièce	4,00	mètres
Longueur de la salle	7,00	mètres

Toutes les dimensions sont à confirmer sur site en fonction des dimensions des briques disponibles: implanter avec les briques

# Savonnerie

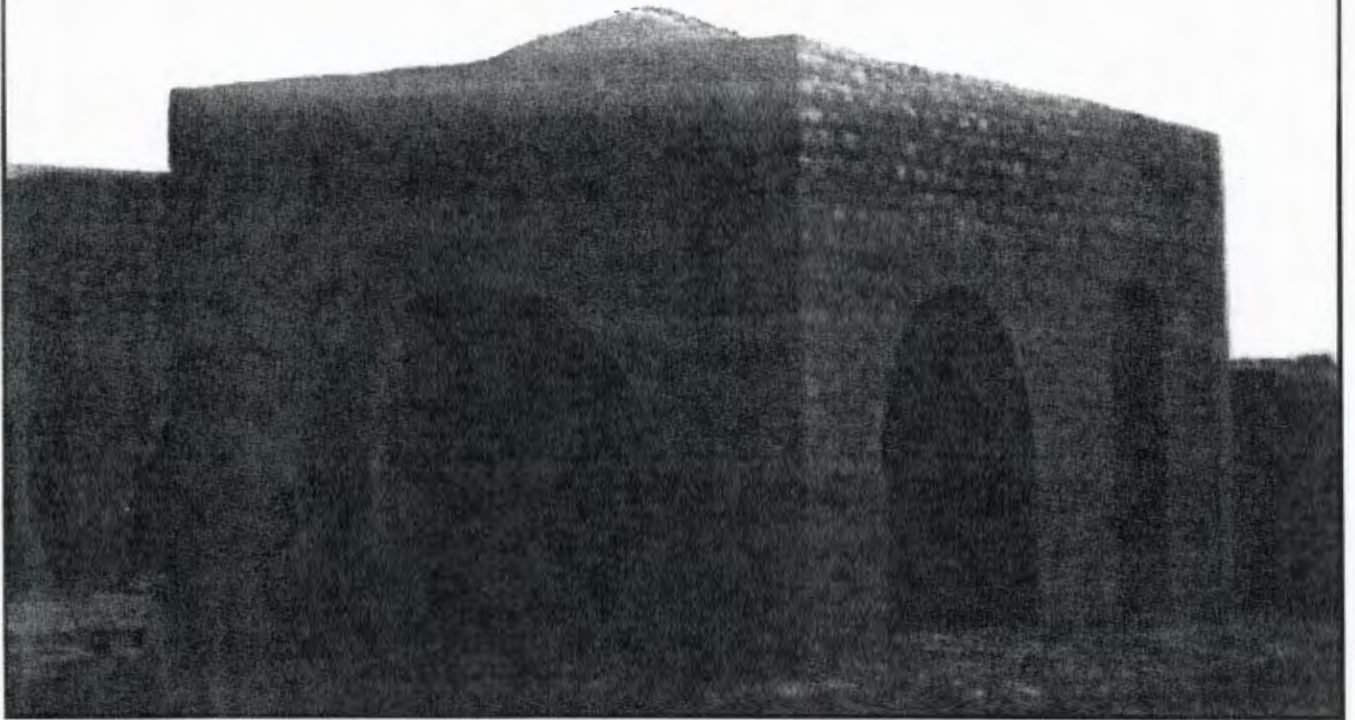

## Devis pour la contribution du groupement villageois

Superficie en m <sup>2</sup>	Durée en nombre de jours	Nombre manœuvres par jour	Grandes briques 38x24x12	Petites briques 20x15x6	Fûts d'eau 200 litres	Charrettes de terre	Charrettes de sable
20	20	15	2500	4200	100	130	10

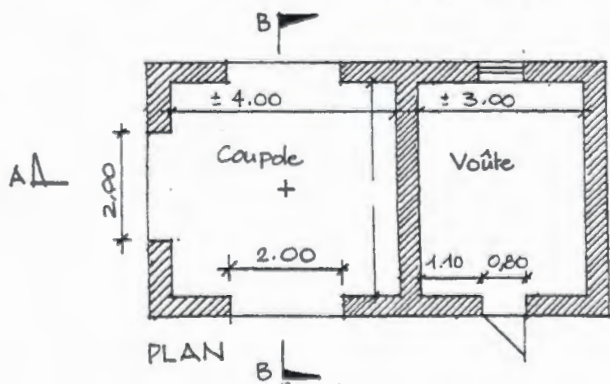
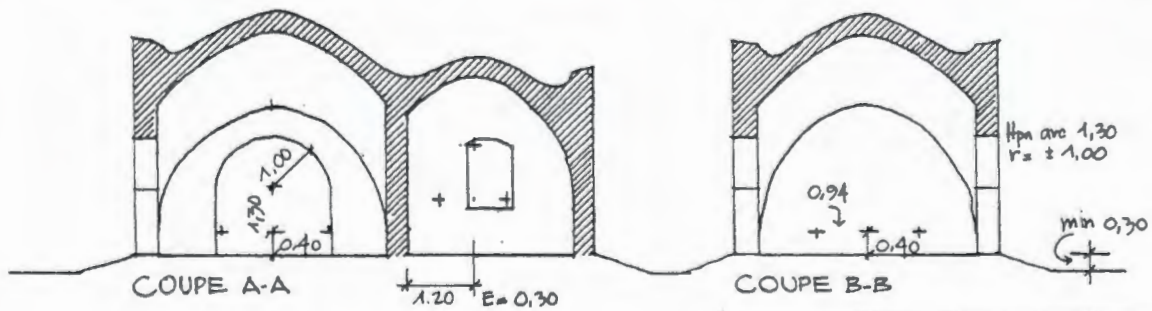

Coordonnées du toit		
Voûte	Hauteur point de naissance	1.00 mètres
	Portée de la voûte	3.60 mètres
	Portée pièce	3.00 mètres
	Excentricité	0.30 mètres
Coupole	Hauteur point de naissance	0.40 mètres
	Déplacement	+/- 0.94 mètres
	Rayon guide	3.77 mètres

Toutes les dimensions sont à confirmer sur site en fonction des dimensions des briques disponibles: implanter avec les briques

# Le bureau – magasin



## Devis pour la contribution du groupement villageois

Superficie en m <sup>2</sup>	Durée en nombre de jours	Nombre manœuvres par jour	Grandes briques 38x24x12	Petites briques 20x15x6	Fûts d'eau 200 litres	Charrettes de terre	Charrettes de sable	Charrettes de gravier	Charrettes de fumier
14	14	15	2300	2700	60	90	10	6	3

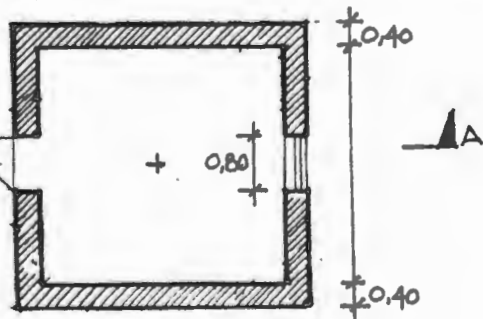
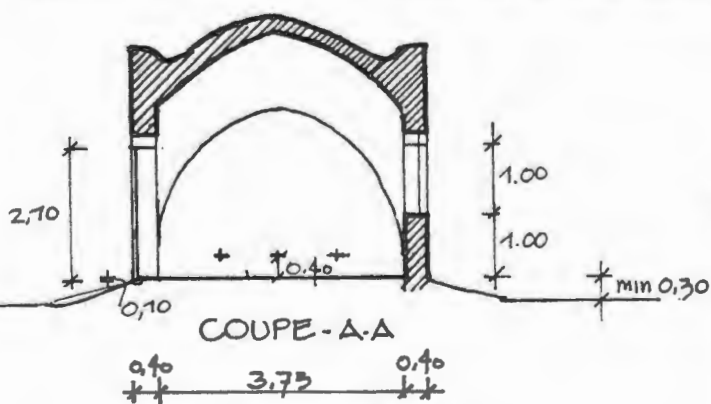

### Coordonnées du toit

Coupoles	Hauteur point de naissance	0.40 mètres
	Déplacement	1/3, soit +/- 0.90
	Dimensions pièces	+/- 3.75 x 3.75

Toutes les dimensions sont à confirmer sur site en fonction des dimensions des briques disponibles: implanter avec les briques

# Four à poterie



Un four a été construit en mai 1998 à Roanga, destiné à améliorer la qualité de la cuisson et à réduire la consommation de combustible lors de la cuisson.

Un premier four a déjà été construit au Mali

## Devis pour la contribution du groupement villageois

Sperficie en m <sup>2</sup>	Durée en nombre de jours	Nombre manoeuvres par jour	Grandes briques 38x24x12	Petites briques 20x15x6	Fûts d'eau 200 litres	Charrettes de terre	Charrettes de sable	Charrettes de gravier	Charrettes de fumier
8	7	10	1500	1200	35	60	1	1	3

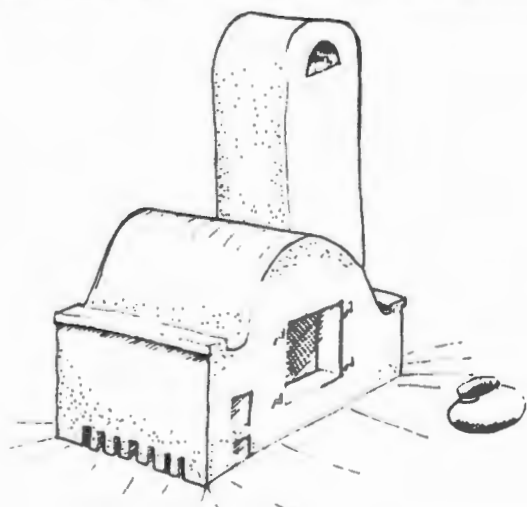

### Coordonnées du toit

Voûte principale	Hauteur point de naissance	0.15 metres au dessus du socle
	Portée de la voûte	2,80 metres
	Dimensions four (socle)	2,00 x 1,60 metres
	Hauteur à l'intérieur	1,90 metres

Toutes les dimensions sont à confirmer sur site en fonction des dimensions des briques disponibles: implanter avec les briques

# Bergerie



## Devis pour la contribution du groupement villageois

Sperficie en m <sup>2</sup>	Durée en nombre de jours	Nombre manœuvres par jour	Grandes briques 38x24x12	Petites briques 20x15x6	Fûts d'eau 200 litres	Charrettes de terre	Charrettes de sable
<b>20</b>	<b>20</b>	<b>15</b>	<b>2500</b>	<b>4200</b>	<b>100</b>	<b>130</b>	<b>10</b>

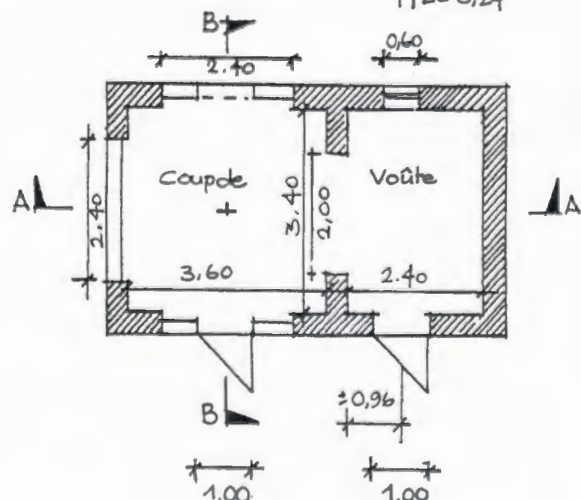
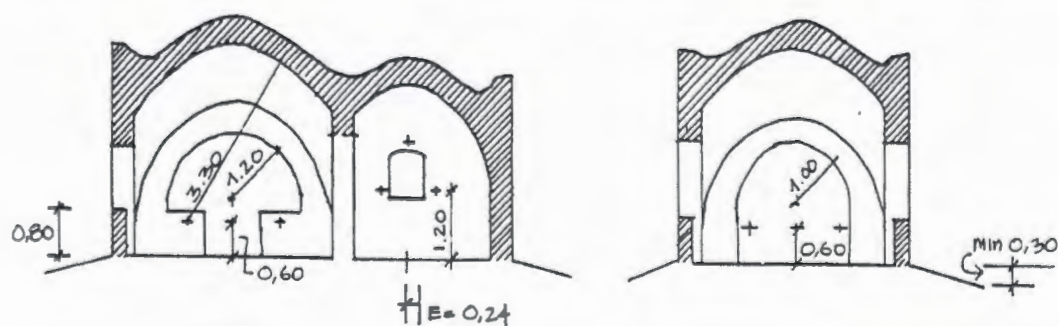

Coordonnées du toit		
Voûte	Hauteur point de naissance	1.20 mètres
	Portée de la voûte	2.88 mètres
	Portée pièce	2.40 mètres
	Excentricité	0.24 mètres
Coupole	Hauteur point de naissance	0.60 mètres
	Déplacement	+/- 0.82 mètres
	Rayon guide	3.30 mètres

Toutes les dimensions sont à confirmer sur site en fonction des dimensions des briques disponibles: implanter avec les briques

## Annex 3

### Additional photographs - interiors



*Photo 14: Agadez craft trading cooperative, Niger, built 1988, seen here in 1998.*



*Photo 15: Meeting place "hangar": a popular building in the Burkina Red Cross programme*





*Photo 16: "Eccentric" vaults give more vertical wall space for modern needs, Mirriah, Niger.*

## Annexe 4

### Background and case study material

BASIN Wall-building case studies, published by GATE/GTZ, 1995:-

- *Woodless Construction – 1 An overview*
- *Woodless Construction – 2 The training of trainers and builders*
- *Woodless Construction – 3 Change and adaptation to local needs*

Building Issues, 1997, n° 2, vol. 9, published by LCHS, 1998:-

*Woodless Construction: Unstabilised earth brick vault and dome roofing without formwork*



Fiche bâtiment:  
UNE PIECE

QUANTITES

Superficie	Temps	Maçons	Mancouvres	Grandes briques	Petites briques	Eau fût 200 l	Banco charrette	Ferrier charrettes	Gravier charrette	Porte	Fenêtre	Gouttière	Autres
14	15 JRS	1 CC 1 MC	4	1995	2900	40	50	1	1	1	SELON CLIENT	4	1 CMT 3 CMT

PLAN D'EXECUTION

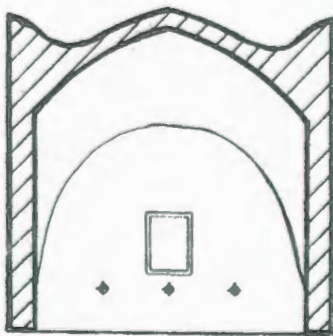

coupe AA

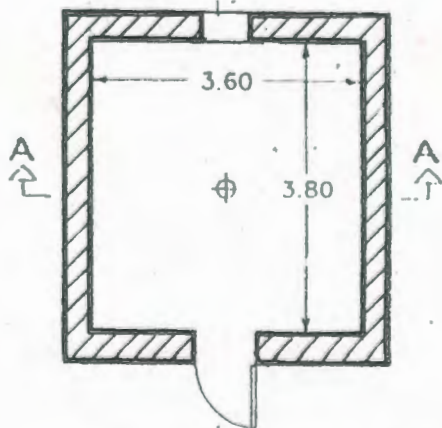

Dimensions coordonnées

Pièce	Toit	Dimension	HPW	D	RC
P	C	360/380	60	87	350

Toutes les dimensions sont à confirmer sur site en fonction des dimensions des briques disponibles: implanter avec les briques

Pour votre confort climatique et la protection contre la pluie, disposer votre bâtiment avec les petites faces vers l'est et l'ouest



Fiche bâtiment:

UNE PIECE

QUANTITES

Superficie	Temps	Maçons	Mansuèvres	Grandes briques	Petites briques	Eau fût 200 l	Banco charrette	Fumier charrettes	Gravier charrette	Porte	Fenêtre	Gouttière	Autres
M2	JOURS	U	U	U	U	Fût	char	CHAR.	CHAR.	U	U	U	U
20	20	1.22 1.12	3MVS	2500	1.100	40	50	1	1	1	2	4	1 CMT 4 CMT

PLAN D'EXECUTION

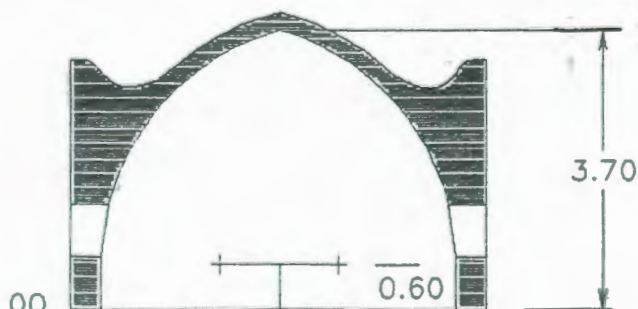

COUPE

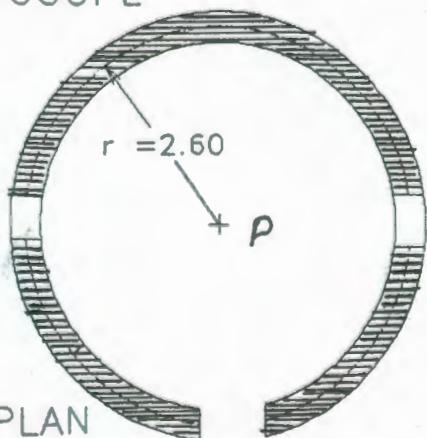

PLAN

Dimensions coordonnées

Pièce	Toit	Dimension	HPN	D	RC
P	C	ΔMT 4.80	60	80	3.20
-	-	-	-	-	-
-	-	-	-	-	-
-	-	-	-	-	-
-	-	-	-	-	-

Toutes les dimensions sont à confirmer sur site en fonction des dimensions des briques disponibles: implanter avec les briques

Pour votre confort climatique et la protection contre la pluie, disposer votre bâtiment avec les petites façades vers l'est et l'ouest.



Fiche bâtiment:  
DEUX PIECES

QUANTITES

Superficie	Temps	Maçons	Manceuvres	Grandes briques	Petites briques	Eau fût 200 l	Banco charrette	Fumier charrette	Gravier charrette	Porte	Fenêtre	Gouttière	Autres
27,40	21 JOURS	1 CC 2 MC		3500	5750	80	98	2	2	SELON	SELON	6	1 CMT 6 CMT

PLAN D'EXECUTION

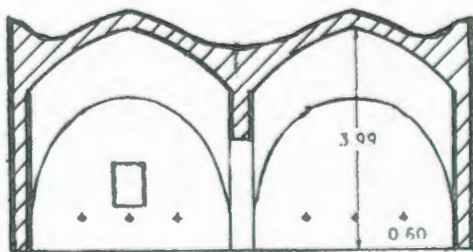

coupe AA

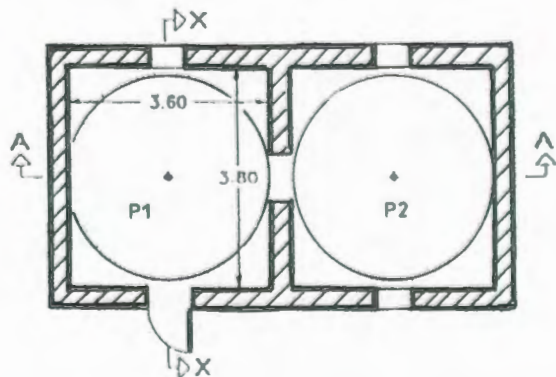

Dimensions coordonnées

Pièce	Toit	Dimension	HPM	D	RC
P1	C	360/380	60	87	35 C
P2	C	360/380	60	87	35 0
—	—	—	—	—	—
—	—	—	—	—	—
—	—	—	—	—	—

Toutes les dimensions sont à confirmer sur site en fonction des dimensions des briques disponibles: implanter avec les briques

Pour votre confort climatique et la protection contre la pluie, disposer votre bâtiment avec les petites façades vers l'est et l'ouest.



**Fiche bâtiment:**  
**TROIS PIÈCES**  
**DEUX ANNEXES**



**QUANTITES**

Superficie	Temps	Maçons	Manceuvres	Grandes briques	Petites briques	Eau (lit 200 l)	Banco charrette	Fumier charrettes	Gravier charrette	Porte	Fenêtre	Gouttière	Autres
53	45	1 CC 4 MC	6	85 00	11.000	160	190	3	8	SELON CLIENT	SELON CLIENT	12	3 CMT 15 CMT

**PLAN D'EXECUTION**

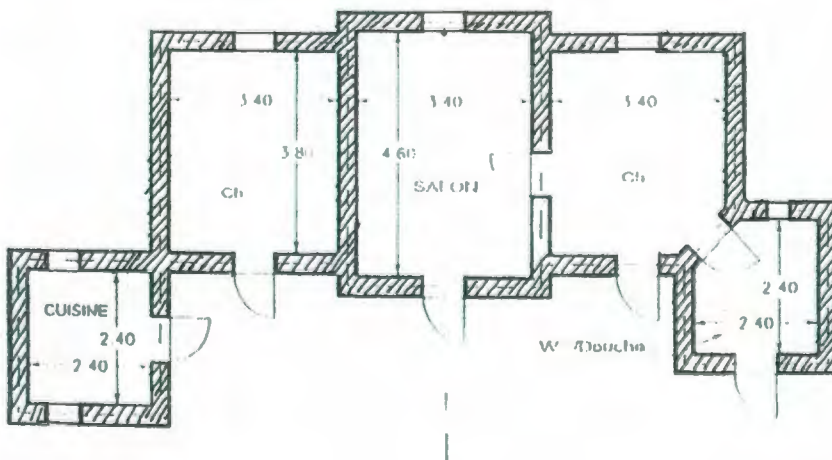

**Dimensions coordonnées**

Pièce	Toit	Dimension	HPN	D	RC
P1	C	340/380	50	85	34.0
P2	V	340/460	125	—	—
P3	C	340/380	50	85	34.0
P4	C	240/240	27.0	0	17.0
P5	C	240/240	123	0	17.0

Toutes les dimensions sont à confirmer sur site en fonction des dimensions des briques disponibles: implanter avec les briques

Pour votre confort climatique et la protection contre la pluie, disposer votre bâtiment avec les petites façades vers l'est et l'ouest.

## **Carte**



Fiche bâtiment:  
TROIS PIECES



QUANTITES

Superficie	Temps	Maçons	Mancuvres	Grandes briques	Petites briques	Eau fût 200 l	Banco charrette	Fumier charrettes	Gravier charrette	Porte	Fenêtre	Gouttière	Autres
44	30 JOUR	1 CC 4 MC	6	7000	9250	130	160	2	6	SELON CLIENT	SELON CLIENT	6	11CMT 2CMT

PLAN D'EXECUTION

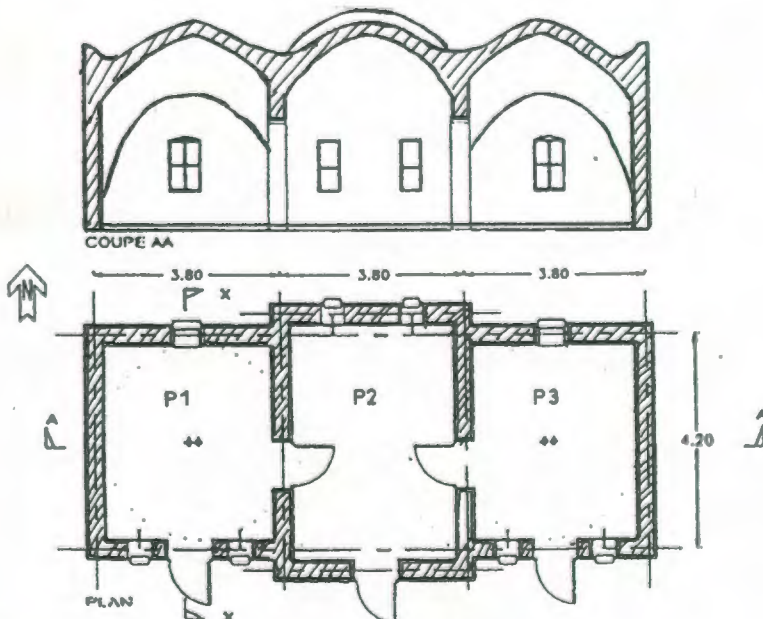

EXCENTRICITE +10

Dimensions coordonnées

Pièce	Toit	Dimension	HPN	D	RC
P1	C	360/380	50	87	349
P2	V	360/460	122	—	—
P3	C	360/380	50	87	349
—	—	—	—	—	—
—	—	—	—	—	—

Toutes les dimensions sont à confirmer sur site en fonction des dimensions des briques disponibles: implanter avec les briques

Pour votre confort climatique et la protection contre la pluie, disposer votre bâtiment avec les petites façades vers l'est et l'ouest

CONSTRUCTION  
SANS BOIS



Unité de Formation et Sensibilisation (UFS)

B.P. 12473 Niamey, République du Niger

Téléphone: 75 28 00 Télécopie: 75 34 48



Fiche bâtiment:  
QUATRE PIÈCES

QUANTITES

Superficie	Temps	Maçons	Mancœuvres	Grandes briques	Petites briques	Eau fût 200 l	Banco charrette	Furter charrettes	Gravier charrette	Porte	Fenêtre	Gouttière	Autres
60	60	1 CC 4 MC	6	9755	12700	180	210	4	8	SELON CLIENT	SELON CLIENT	10	3 CMT 1 CMT

PLAN D'EXECUTION

CMT= SAC DE CIMENT

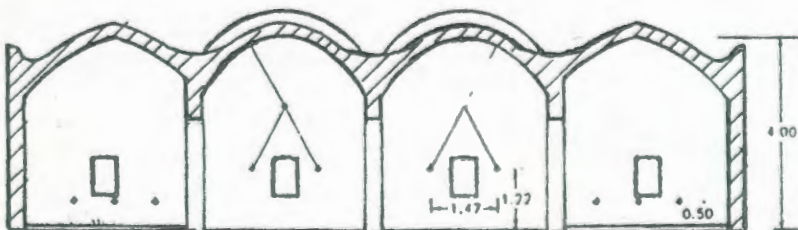

coupe AA

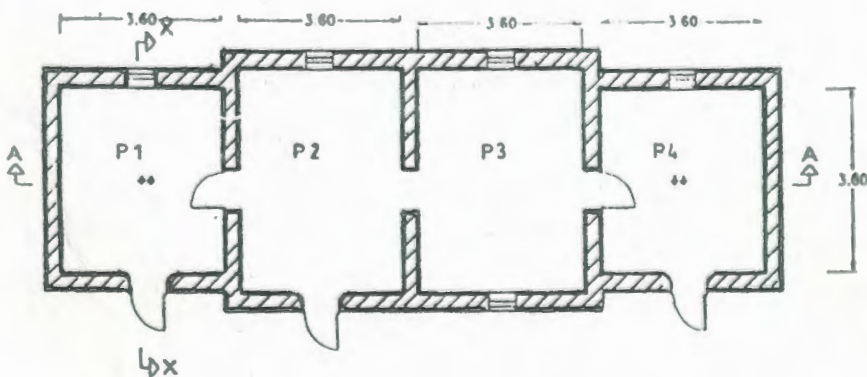

Dimensions coordonnées

Pièce	Toit	Dimension	HPW	D	RC
P1	C	360/380	50	87	350
P2	V	360/460	122	—	—
P3	V	360/460	122	—	—
P4	C	360/380	50	87	350
—	—	—	—	—	—

Toutes les dimensions sont à confirmer sur site en fonction des dimensions des briques disponibles: Implanter avec les briques

Pour votre confort climatique et la protection contre la pluie, disposer votre bâtiment avec les petites façades vers l'est et l'ouest



Fiche bâtiment:  
DEUX PIECES



QUANTITES

Superficie	Temps	Maçons	Manceuvres	Grandes briques	Petites briques	Eau fût 200 l	Banco charrette	Fumier charrettes	Gravier charrette	Porte	Fenêtre	Gouttière	Autres
252	30	1. C.C 4 M.C	8	4 150	5525	85	100	3	3	1	3	6	1. C.MI 6. C.MT

PLAN D'EXECUTION

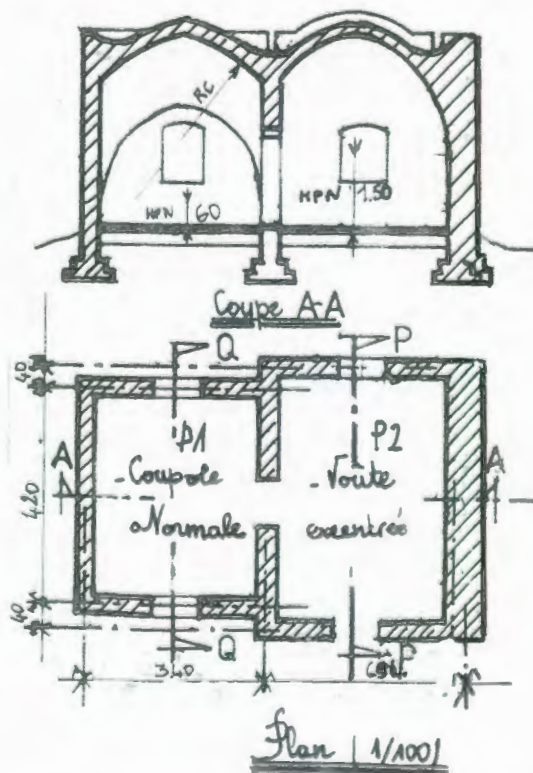

Dimensions coordonnées

Pièce	Toit	Dimension	HPN	D	RC
P1	C	300/380	60	81	3.23
P2	V	300/460	150	—	—
—	—	—	—	—	—
—	—	—	—	—	—
—	—	—	—	—	—

Toutes les dimensions sont à confirmer sur site en fonction des dimensions des briques disponibles: implanter avec les briques

Pour votre confort climatique et la protection contre la pluie, disposer votre bâtiment avec les petites façades vers l'est et l'ouest.



Fiche bâtiment:

BANQUE CÉREALIÈRE  
SALLE D'ALPHABÉTISATION



QUANTITES

Superficie	Temps	Maçons	Manceuvres	Grandes briques	Petites briques	Eau fût 200 l	Banco charrette	Fumier charrettes	Gravier charrette	Porte	Fenêtre	Gouttière	Autres
M2	JOURS	U	U	U	U	FUT	CHAR.	CHAR.	CHAR.	U	U	U	U
28	30	1 CC 4 MC	8	6,000	5,000	100	100	15	30	1 (120/220)	4	6	10 ÇMT 2 JOINTS

PLAN D'EXECUTION

Coupe AA

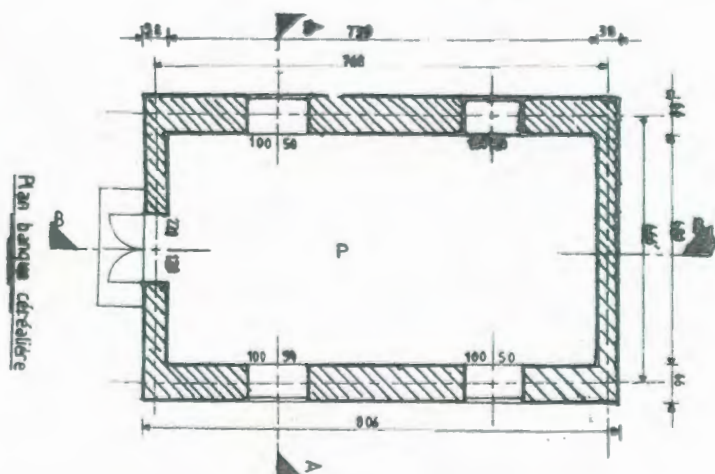
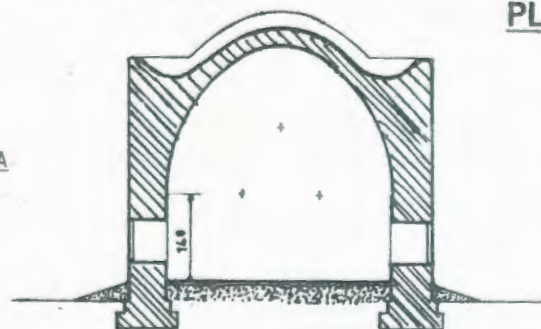

Dimensions coordonnées

Pièce	ToR	Dimension	HPW	D	RC
P	V	400/700	140	—	—
—	—	—	—	—	—
—	—	—	—	—	—
—	—	—	—	—	—
—	—	—	—	—	—

Toutes les dimensions sont à confirmer sur site en fonction des dimensions des briques disponibles: implanter avec les briques

Pour votre confort climatique et la protection contre la pluie, disposer votre bâtiment avec les petites



## FICHE D'IDENTIFICATION DE BATIMENT CSB

Localité : \_\_\_\_\_ Quartier/Dep/Arr \_\_\_\_\_

Nom du responsable : \_\_\_\_\_

Fonction/type du bâtiment : \_\_\_\_\_

Date de construction : \_\_\_\_\_

Chef d'équipe : \_\_\_\_\_

Maçons : 1) \_\_\_\_\_ 4) \_\_\_\_\_

2) \_\_\_\_\_ 5) \_\_\_\_\_

3) \_\_\_\_\_ 6) \_\_\_\_\_

**Pointage :**

Heures M.O.	Heures maçons	Heures chefs de chantier	N° grandes briques	N° petites briques	Terra/banco	Eau	Fumier	Sable	Gravier

Ciment (sac)	Pointes (paquet/1kg)	Fil de fer (rouleau/5kg)	Menuiserie	
			Porte	Fenêtres
<i>Prix unitaire</i>				

Observations : \_\_\_\_\_

\_\_\_\_\_

\_\_\_\_\_

\_\_\_\_\_

\_\_\_\_\_

\_\_\_\_\_

\_\_\_\_\_

- Pièces jointes :**
- 1) Plan
  - 2) Photo
  - 3) Contrat
  - 4) P.V. / fiches de suivi
  - 5) Autre : \_\_\_\_\_

Fiche établi par : .....

Date : .....

